



# reventon

INDUSTRIAL SOLUTIONS

## Technical documentation

AIR WATER HEATERS IN EPP CASING HC-3S SERIES

**MODELS:**

HC 20-3S

HC 30-3S

HC 35-3S

HC 45-3S

HC 50-3S

HC 70-3S

HC 80-3S



EN

- 1. INTRODUCTION
  - 1.1 PRECAUTIONS
  - 1.2 TRANSPORT
  - 1.3 PACKAGE CONTENT
  - 1.4 USE
- 2. DEVICE CHARACTERISTICS
  - 2.1 CONSTRUCTION AND PRINCIPLE OF OPERATION
  - 2.2 DEVICE DIMENSIONS
  - 2.3 DEVICE TECHNICAL DATA
- 3. ASSEMBLY
  - 3.1 GENERAL PRINCIPLES
  - 3.2 ROTATING MOUNTING BRACKET
- 4. INSTALLATION INSTRUCTIONS
  - 4.1 CONNECTION OF THE DEVICE TO THE HYDAULIC SYSTEM
  - 4.2 CONNECTION OF THE DEIVCE TO THE ELECTRICAL SYSTEM
- 5. PRECAUTIONS & WARNINGS
- 6. CONTROLS
- 7. CONNECTION SCHEMES
  - 7.1 MODELS FOR HC 20-3S, HC 30-3S, HC 35-3S, HC 45-3S, HC 50-3S, HC 80-3S.
  - 7.2 MODEL FOR HC 70-3S
- 8. TERMS OF WARRANTY

**1. INTRODUCTION**

Thank you very much for purchasing air water heater HC-3S. We would like to congratulate you on excellent choice. Please read and keep this manual.

**1.1 PRECAUTIONS**

The buyer and the user of the air water heater Reventon Group brand should read carefully the following instructions and proceed to the content recommendations. Proceeding due to the following instruction guarantees the correct usage and safety. In case of any doubts please contact directly Reventon Group sp. z o. o. [Ltd.]. The producer reserves the rights to make changes to the technical documentation without previous notice. Reventon Group sp. z o. o. [Ltd.] is not responsible for the damages which occur due to improper installation, not keeping the device in repair or using the device out of line. The installation should be carried out by the professional installers, who possess the qualifications to install these types of devices. The installers are responsible for making the installation as instructed in the technical data. In case of unserviceable please plug out the device and contact with the authorized for repair person or the supplier. During the installation, use, service and periodical inspections all regulations and safety rules must be followed.

**1.2 TRANSPORT**

During the acceptance of goods, it is needed to check the device to exclude any damages. During the transport, it is needed to use the proper equipment, it is necessary to carry the device by two people. In case of any damages please fill in the damage report in presence of the supplier.

**1.3 PACKAGE CONTENT**

- heater
- operation and maintenance manual and warranty card

**1.4 USE**

Heating devices Reventon Group HC series are used to heat spaces such as: production halls, warehouses, commercial room, service spaces, garages, workshops, greenhouses, tents, shops, malls, shopping malls etc. However, heating devices should not be used in corrosive environments for aluminum, copper and steel as well as in highly dusty environments (above 0.3 g/m<sup>3</sup>). The devices should not be installed in rooms where they would be exposed to high humidity or direct contact with water.

**2. DEVICE CHARACTERISTICS**

**2.1 CONSTRUCTION AND PRINCIPLE OF OPERATION**

**Casing:** made of expanded polypropylene (EPP). This material is characterized by low density (light weighted) and high chemical and physical resistance. It has an excellent sound and thermal insulation properties. Moreover, material is environmentally friendly and "green", i.e. 100% recyclable.

**Air stators:** made of polypropylene PP. It is possible to adjust manually the air stators to achieve the needed direction of the air flow. There are also versions with confusor (increased airflow range) or with diffuser 360° (better mixing of supplied and room air).

**Heating coil:** made of copper and aluminum. Supplied by distribution medium (heating or cooling), which circulates through the coil and releases or extracts heat from the air. The coil has the following technical parameters: the maximum temperature of the heating factor is 120°C, maximum pressure 1.6 MPa, headers diameter ¾". Depending on dimensions of the device the heaters are equipped with 1, 2 or 3-row heating coils.

**Axial blowing fan:** made of steel. The objective of the fan is to ensure air flow through the exchanger. It has a single-phase, three speed motor with the following parameters: protection degree IP54, rate current 0.54-2.20 A (depending on model and operating mode). Fans have diameter 400 mm (HC 20-3S, HC 30-3S, HC 35-3S and HC 45-3S) or 450 mm (HC 50-3S, HC 70-3S and HC 80-3S).

**Rotating mounting bracket (optional equipment):** enables the device to be installed in several configurations (depending on the requirements) and the unit to be rotated in a horizontal plane.

**2.2 DEVICEDIMENSIONS**

- HC 20-3S, HC 30-3S, HC 35-3S and HC 45-3S:

- height (A): 598 mm
- width (B): 636 mm
- depth (C): 340 mm

- HC 50-3S, HC 70-3S and HC 80-3S:

- height (A): 698 mm
- width (B): 739 mm
- depth (C): 360 mm

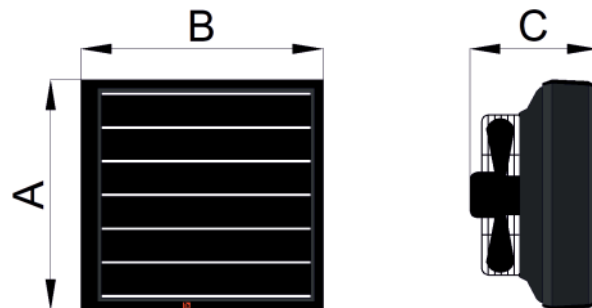

Heating coil: made of copper and aluminum. Supplied by distribution medium (heating or cooling), which circulates through the coil and releases or extracts heat from the air. The coil has the following technical parameters: the maximum temperature of the heating factor is 120°C, maximum pressure 1.6 MPa, headers diameter ¾". Depending on dimensions of the device the heaters are equipped with 1, 2 or 3-row heating coils.

Axial blowing fan: made of steel. The objective of the fan is to ensure air flow through the exchanger. It has a single-phase, three speed motor with the following parameters: protection degree IP54, rate current 0.54-2.20 A (depending on model and operating mode). Fans have diameter 400 mm (HC 20-3S, HC 30-3S, HC 35-3S and HC 45-3S) or 450 mm (HC 50-3S, HC 70-3S and HC 80-3S).

Rotating mounting bracket (optional equipment): enables the device to be installed in several configurations (depending on the requirements) and the unit to be rotated in a horizontal plane.

**2.2 DEVICEDIMENSIONS**

- HC 20-3S, HC 30-3S, HC 35-3S and HC 45-3S:

- height (A): 598 mm
- width (B): 636 mm
- depth (C): 340 mm

- HC 50-3S, HC 70-3S and HC 80-3S:

- height (A): 698 mm
- width (B): 739 mm
- depth (C): 360 mm

## 2.3 DEVICE TECHNICAL DATA

TECHNICAL DATA Product code		HC 20-3S WHHC20-3S-1759	HC 30-3S WHHC30-3S-1760	HC 35-3S WHHC35-3S-1761	HC 45-3S WHHC45-3S-1762	HC 50-3S* WHHC50-3S-2006	HC 70-3S WHHC70-3S-1764	HC 80-3S* WHHC80-3S-1956
Nominal heating capacity [kW] **	III STAGE	21.4	26.4	30.3	42.0	49.8	60.6	69.2
	II STAGE	17.3	20.3	22.9	28.9	45.2	40.1	61.5
	I STAGE	13.3	15.5	17.3	21.1	34.6	32.7	46.5
Heating capacity range [kW] ***		1.55 – 28.4	1.8 – 34.9	2.14 – 40.1	3.21 – 55.6	5.00 – 65.8	5.0 – 80.1	6.96-91.5
Maximum airflow [m <sup>3</sup> /h]	III STAGE	3200	3100	2700	2500	5000	3400	4200
	II STAGE	2150	1950	1700	1450	4200	1900	3500
	I STAGE	1350	1250	1100	950	2600	1450	2300
Maximum horizontal range [m]		19	18	15	14	24	18	21
Number of rows [pcs.]		1	1	2	2	2	3	3
Capacity of water [dm <sup>3</sup> ]		0.65	0.8	1.35	1.7	1.95	2.85	2.85
Maximum temperature of working fluid [°C]		120	120	120	120	120	120	120
Maximum working pressure [MPa]		1.6	1.6	1.6	1.6	1.6	1.6	1.6
Connection diameter ["]		3/4	3/4	3/4	3/4	3/4	3/4	3/4
Supply voltage [V] / Supply frequency [Hz]		230/50	230/50	230/50	230/50	230/50	230/50	230/50
Rated motor current [A]	III STAGE	0.84	0.84	0.84	0.84	2.20	1.08	2.20
	II STAGE	0.65	0.65	0.65	0.65	1.70	0.86	1.70
	I STAGE	0.54	0.54	0.54	0.54	1.50	0.70	1.50
Motor speed [rpm]	III STAGE	1400	1400	1400	1400	1350	1360	1350
	II STAGE	1050	1050	1050	1050	1200	1050	1200
	I STAGE	750	750	750	750	750	750	750
Motor power [W]	III STAGE	190	190	190	190	480	240	480
	II STAGE	150	150	150	150	350	190	350
	I STAGE	120	120	120	120	280	160	280
Protection degree IP [-]		54	54	54	54	54	54	54
Net weight [kg]		11.5	12	12.5	14	20.5	19.5	22.5
Noise [dB]****	III STAGE	55	55	54	54	62	58	61
	II STAGE	49	49	48	48	57	53	56
	I STAGE	47	47	46	46	51	49	51

\* not compatible with speed controllers like the fan speed controller HC and the thyristor speed controller TRO

\*\* for parameters 90/70°C and 0°C inlet air temperature

\*\*\* max. 120/90°C, 0°C inlet air temperature, III stage // min. 40/30°C, 20°C inlet air temperature, I stage

\*\*\*\* measurement at the distance 5 m

Parameters	HC 20-3S-3 stage 3200 m <sup>3</sup> /h				
Supply/return water temperature [°C]	120/90				
Dry bulb air inlet temperature [°C]	0	5	10	15	20
Heating capacity [kW]	28.4	26.6	24.8	23.1	21.4
Dry bulb air outlet temperature [°C]	24.7	28.5	32.4	36.2	40
Water flow [m <sup>3</sup> /h]	0.84	0.78	0.73	0.68	0.63
Pressure drop in the heat exchanger [kPa]	4	4	3	3	3

Parameters	HC 20-3S-3 stage 3200 m <sup>3</sup> /h				
Supply/return water temperature [°C]	90/70				
Dry bulb air inlet temperature [°C]	0	5	10	15	20
Heating capacity [kW]	21.4	19.7	18	16.4	14.7
Dry bulb air outlet temperature [°C]	18.6	22.4	26.2	30	33.8
Water flow [m <sup>3</sup> /h]	0.94	0.87	0.79	0.72	0.65
Pressure drop in the heat exchanger [kPa]	6	5	4	3	3

Parameters	HC 20-3S-3 stage 3200 m <sup>3</sup> /h				
Supply/return water temperature [°C]	80/60				
Dry bulb air inlet temperature [°C]	0	5	10	15	20
Heating capacity [kW]	18.1	16.4	14.7	13.1	11.5
Dry bulb air outlet temperature [°C]	15.7	19.5	23.3	27	30.8
Water flow [m <sup>3</sup> /h]	0.79	0.72	0.65	0.58	0.51
Pressure drop in the heat exchanger [kPa]	4	3	3	2	2

Parameters	HC 20-3S-3 stage 3200 m <sup>3</sup> /h				
Supply/return water temperature [°C]	70/50				
Dry bulb air inlet temperature [°C]	0	5	10	15	20
Heating capacity [kW]	14.7	13.1	11.5	9.90	8.37
Dry bulb air outlet temperature [°C]	12.8	16.6	20.3	24.1	27.8
Water flow [m <sup>3</sup> /h]	0.64	0.57	0.50	0.43	0.37
Pressure drop in the heat exchanger [kPa]	3	2	2	1	1

Parameters	HC 20-3S-3 stage 3200 m <sup>3</sup> /h				
Supply/return water temperature [°C]	50/30				
Dry bulb air inlet temperature [°C]	0	5	10	15	20
Heating capacity [kW]	7.95	6.44	4.98	3.55	2.18
Dry bulb air outlet temperature [°C]	6.9	10.7	14.5	18.3	22.0
Water flow [m <sup>3</sup> /h]	0.35	0.28	0.22	0.15	0.09
Pressure drop in the heat exchanger [kPa]	1	1	0	0	0

Parameters	HC 20-3S-3 stage 3200 m <sup>3</sup> /h				
Supply/return water temperature [°C]	40/30				
Dry bulb air inlet temperature [°C]	0	5	10	15	20
Heating capacity [kW]	8.31	6.76	5.25	3.78	2.36
Dry bulb air outlet temperature [°C]	7.2	11	14.7	18.5	22.2
Water flow [m <sup>3</sup> /h]	0.72	0.59	0.45	0.33	0.20
Pressure drop in the heat exchanger [kPa]	4	3	2	1	0

Parameters	HC 30-3S-3 stage 3100 m <sup>3</sup> /h				
Supply/return water temperature [°C]	120/90				
Dry bulb air inlet temperature [°C]	0	5	10	15	20
Heating capacity [kW]	34.9	32.7	30.6	28.4	26.3
Dry bulb air outlet temperature [°C]	31.4	34.9	38.4	41.9	45.4
Water flow [m <sup>3</sup> /h]	1.03	0.97	0.9	0.84	0.78
Pressure drop in the heat exchanger [kPa]	6	6	5	4	4

Parameters	HC 30-3S-3 stage 3100 m <sup>3</sup> /h				
Supply/return water temperature [°C]	90/70				
Dry bulb air inlet temperature [°C]	0	5	10	15	20
Heating capacity [kW]	26.4	24.2	22.1	20.1	18.1
Dry bulb air outlet temperature [°C]	23.7	27.1	30.6	34	37.4
Water flow [m <sup>3</sup> /h]	1.16	1.07	0.98	0.89	0.8
Pressure drop in the heat exchanger [kPa]	8	7	6	5	4

Parameters	HC 30-3S-3 stage 3100 m <sup>3</sup> /h				
Supply/return water temperature [°C]	80/60				
Dry bulb air inlet temperature [°C]	0	5	10	15	20
Heating capacity [kW]	22.2	20.1	18.1	16.1	14.2
Dry bulb air outlet temperature [°C]	19.9	23.4	26.8	30.2	33.6
Water flow [m <sup>3</sup> /h]	0.97	0.88	0.79	0.71	0.62
Pressure drop in the heat exchanger [kPa]	6	5	4	3	3

Parameters	HC 30-3S-3 stage 3100 m3/h				
Supply/return water temperature [°C]	70/50				
Dry bulb air inlet temperature [°C]	0	5	10	15	20
Heating capacity [kW]	18	16	14	12.1	10.2
Dry bulb air outlet temperature [°C]	16.2	19.6	23.1	26.5	29.8
Water flow [m³/h]	0.79	0.7	0.61	0.53	0.45
Pressure drop in the heat exchanger [kPa]	4	3	3	2	1

Parameters	HC 30-3S-3 stage 3100 m3/h				
Supply/return water temperature [°C]	50/30				
Dry bulb air inlet temperature [°C]	0	5	10	15	20
Heating capacity [kW]	9.68	7.82	6.0	4.25	2.58
Dry bulb air outlet temperature [°C]	8.7	12.1	15.6	19.0	22.5
Water flow [m³/h]	0.42	0.34	0.26	0.18	0.11
Pressure drop in the heat exchanger [kPa]	1	1	1	0	0

Parameters	HC 30-3S-3 stage 3100 m3/h				
Supply/return water temperature [°C]	40/30				
Dry bulb air inlet temperature [°C]	0	5	10	15	20
Heating capacity [kW]	10.2	8.27	6.4	4.58	2.84
Dry bulb air outlet temperature [°C]	9.1	12.6	16.0	19.3	22.7
Water flow [m³/h]	0.88	0.72	0.55	0.4	0.25
Pressure drop in the heat exchanger [kPa]	5	4	2	1	0

Parameters	HC 35-3S-3 stage 2700 m3/h				
Supply/return water temperature [°C]	120/90				
Dry bulb air inlet temperature [°C]	0	5	10	15	20
Heating capacity [kW]	40.1	37.6	35.1	32.7	30.3
Dry bulb air outlet temperature [°C]	41.3	44.4	47.5	50.5	53.5
Water flow [m³/h]	1.18	1.11	1.04	0.97	0.89
Pressure drop in the heat exchanger [kPa]	5	4	4	3	3

Parameters	HC 35-3S-3 stage 2700 m3/h				
Supply/return water temperature [°C]	90/70				
Dry bulb air inlet temperature [°C]	0	5	10	15	20
Heating capacity [kW]	30.3	27.9	25.5	23.2	20.9
Dry bulb air outlet temperature [°C]	31.2	34.2	37.2	40.2	43.1
Water flow [m³/h]	1.33	1.23	1.12	1.02	0.92
Pressure drop in the heat exchanger [kPa]	6	5	4	4	3

Parameters	HC 35-3S-3 stage 2700 m3/h				
Supply/return water temperature [°C]	80/60				
Dry bulb air inlet temperature [°C]	0	5	10	15	20
Heating capacity [kW]	25.6	23.3	21	18.7	16.5
Dry bulb air outlet temperature [°C]	26.4	29.4	32.4	35.3	38.2
Water flow [m³/h]	1.13	1.02	0.92	0.82	0.72
Pressure drop in the heat exchanger [kPa]	4	4	3	2	2

Parameters	HC 35-3S-3 stage 2700 m3/h				
Supply/return water temperature [°C]	70/50				
Dry bulb air inlet temperature [°C]	0	5	10	15	20
Heating capacity [kW]	21.0	18.7	16.4	14.2	12.1
Dry bulb air outlet temperature [°C]	21.6	24.6	27.6	30.5	33.4
Water flow [m³/h]	0.92	0.82	0.72	0.62	0.53
Pressure drop in the heat exchanger [kPa]	3	2	2	1	1

Parameters	HC 35-3S-3 stage 2700 m3/h				
Supply/return water temperature [°C]	50/30				
Dry bulb air inlet temperature [°C]	0	5	10	15	20
Heating capacity [kW]	11.6	9.48	7.4	5.36	3.38
Dry bulb air outlet temperature [°C]	12.0	14.9	17.9	20.8	23.7
Water flow [m³/h]	0.50	0.41	0.32	0.23	0.15
Pressure drop in the heat exchanger [kPa]	1	1	0	0	0

Parameters	HC 35-3S-3 stage 2700 m3/h				
Supply/return water temperature [°C]	40/30				
Dry bulb air inlet temperature [°C]	0	5	10	15	20
Heating capacity [kW]	11.9	9.71	7.59	5.52	3.51
Dry bulb air outlet temperature [°C]	12.2	15.2	18.1	21.0	23.9
Water flow [m³/h]	1.03	0.84	0.66	0.48	0.30
Pressure drop in the heat exchanger [kPa]	4	3	2	1	0

Parameters	HC 45-3S-3 stage 2500 m3/h				
Supply/return water temperature [°C]	120/90				
Dry bulb air inlet temperature [°C]	0	5	10	15	20
Heating capacity [kW]	55.6	52.1	48.8	45.6	42.4
Dry bulb air outlet temperature [°C]	61.8	64.1	66.3	68.5	70.7
Water flow [m³/h]	1.64	1.54	1.44	1.35	1.25
Pressure drop in the heat exchanger [kPa]	21	19	17	15	13

Parameters	HC 45-3S-3 stage 2500 m3/h				
Supply/return water temperature [°C]	90/70				
Dry bulb air inlet temperature [°C]	0	5	10	15	20
Heating capacity [kW]	42.0	38.8	35.6	32.5	29.5
Dry bulb air outlet temperature [°C]	46.7	48.9	51.1	53.2	55.2
Water flow [m³/h]	1.85	1.71	1.57	1.43	1.3
Pressure drop in the heat exchanger [kPa]	27	24	20	17	14

Parameters	HC 45-3S-3 stage 2500 m3/h				
Supply/return water temperature [°C]	80/60				
Dry bulb air inlet temperature [°C]	0	5	10	15	20
Heating capacity [kW]	36.2	33.0	29.9	26.9	24.0
Dry bulb air outlet temperature [°C]	40.3	42.4	44.5	46.6	48.6
Water flow [m³/h]	1.59	1.45	1.31	1.18	1.05
Pressure drop in the heat exchanger [kPa]	21	18	15	12	10

Parameters	HC 45-3S-3 stage 2500 m3/h				
Supply/return water temperature [°C]	70/50				
Dry bulb air inlet temperature [°C]	0	5	10	15	20
Heating capacity [kW]	30.3	27.2	24.2	21.2	18.3
Dry bulb air outlet temperature [°C]	33.7	35.8	37.9	39.9	41.9
Water flow [m³/h]	1.33	1.19	1.06	0.93	0.8
Pressure drop in the heat exchanger [kPa]	16	13	10	8	6

Parameters	HC 45-3S-3 stage 2500 m3/h				
Supply/return water temperature [°C]	50/30				
Dry bulb air inlet temperature [°C]	0	5	10	15	20
Heating capacity [kW]	18.4	15.4	12.5	9.65	6.78
Dry bulb air outlet temperature [°C]	20.4	22.5	24.4	26.3	28.1
Water flow [m³/h]	0.8	0.67	0.54	0.42	0.29
Pressure drop in the heat exchanger [kPa]	7	5	3	2	1

Parameters	HC 45-3S-3 stage 2500 m3/h				
Supply/return water temperature [°C]	40/30				
Dry bulb air inlet temperature [°C]	0	5	10	15	20
Heating capacity [kW]	17.4	14.4	11.6	8.78	6.02
Dry bulb air outlet temperature [°C]	19.3	21.3	23.4	25.3	27.2
Water flow [m³/h]	1.5	1.25	1.0	0.76	0.52
Pressure drop in the heat exchanger [kPa]	21	15	10	6	3

Parameters	HC 50-3S-3 stage 5000 m3/h				
Supply/return water temperature [°C]	120/90				
Dry bulb air inlet temperature [°C]	0	5	10	15	20
Heating capacity [kW]	65.8	61.9	58.1	54.4	50.7
Dry bulb air outlet temperature [°C]	37.1	40.4	43.7	47.0	50.2
Water flow [m³/h]	1.94	1.83	1.72	1.61	1.50
Pressure drop in the heat exchanger [kPa]	16	14	13	11	10

Parameters	HC 50-3S-3 stage 5000 m3/h				
Supply/return water temperature [°C]	90/70				
Dry bulb air inlet temperature [°C]	0	5	10	15	20
Heating capacity [kW]	49.8	46.1	42.5	38.8	35.3
Dry bulb air outlet temperature [°C]	28.1	31.4	34.6	37.9	41.1
Water flow [m³/h]	2.19	2.03	1.87	1.71	1.56
Pressure drop in the heat exchanger [kPa]	21	18	16	13	11

Parameters	HC 50-3S-3 stage 5000 m3/h				
Supply/return water temperature [°C]	80/60				
Dry bulb air inlet temperature [°C]	0	5	10	15	20
Heating capacity [kW]	42.8	39.1	35.5	32.0	28.5
Dry bulb air outlet temperature [°C]	24.1	27.4	30.6	33.8	37.0
Water flow [m³/h]	1.88	1.72	1.56	1.40	1.25
Pressure drop in the heat exchanger [kPa]	16	14	11	9	8

Parameters	HC 50-3S-3 stage 5000 m3/h				
Supply/return water temperature [°C]	70/50				
Dry bulb air inlet temperature [°C]	0	5	10	15	20
Heating capacity [kW]	35.7	32.1	28.5	25.1	21.6
Dry bulb air outlet temperature [°C]	20.1	23.4	26.6	29.7	32.9
Water flow [m³/h]	1.56	1.40	1.25	1.10	0.95
Pressure drop in the heat exchanger [kPa]	12	10	8	6	5

Parameters	HC 50-3S-3 stage 5000 m3/h				
Supply/return water temperature [°C]	50/30				
Dry bulb air inlet temperature [°C]	0	5	10	15	20
Heating capacity [kW]	21.4	17.9	14.5	11.1	7.73
Dry bulb air outlet temperature [°C]	12.0	15.2	18.4	21.5	24.6
Water flow [m³/h]	0.93	0.78	0.63	0.48	0.34
Pressure drop in the heat exchanger [kPa]	5	3	2	1	1

Parameters	HC 50-3S-3 stage 5000 m3/h				
Supply/return water temperature [°C]	40/30				
Dry bulb air inlet temperature [°C]	0	5	10	15	20
Heating capacity [kW]	20.5	17.0	13.6	10.3	7.01
Dry bulb air outlet temperature [°C]	11.5	14.7	17.9	21.1	24.2
Water flow [m³/h]	1.77	1.47	1.18	0.89	0.61
Pressure drop in the heat exchanger [kPa]	16	11	7	4	2

Parameters	HC 70-3S-3 stage 3400 m3/h				
Supply/return water temperature [°C]	120/90				
Dry bulb air inlet temperature [°C]	0	5	10	15	20
Heating capacity [kW]	80.1	75.2	70.5	65.8	61.2
Dry bulb air outlet temperature [°C]	65.6	67.7	69.8	71.8	73.7
Water flow [m³/h]	2.37	2.22	2.08	1.94	1.81
Pressure drop in the heat exchanger [kPa]	18	16	14	12	11

Parameters	HC 70-3S-3 stage 3400 m3/h				
Supply/return water temperature [°C]	90/70				
Dry bulb air inlet temperature [°C]	0	5	10	15	20
Heating capacity [kW]	60.6	55.9	51.4	46.9	42.6
Dry bulb air outlet temperature [°C]	49.6	51.6	53.6	55.5	57.4
Water flow [m³/h]	2.67	2.46	2.26	2.07	1.88
Pressure drop in the heat exchanger [kPa]	23	20	17	14	12

Parameters	HC 70-3S-3 stage 3400 m3/h				
Supply/return water temperature [°C]	80/60				
Dry bulb air inlet temperature [°C]	0	5	10	15	20
Heating capacity [kW]	52.2	47,6	43,2	38,8	34,6
Dry bulb air outlet temperature [°C]	42.7	44.7	46.7	48.5	50.4
Water flow [m³/h]	2.29	2.09	1.90	1.71	1.52
Pressure drop in the heat exchanger [kPa]	17	15	12	10	8

Parameters	HC 70-3S-3 stage 3400 m3/h				
Supply/return water temperature [°C]	70/50				
Dry bulb air inlet temperature [°C]	0	5	10	15	20
Heating capacity [kW]	43.8	39.3	35.0	30.7	26,6
Dry bulb air outlet temperature [°C]	35.8	37.8	39.7	41.5	43,3
Water flow [m³/h]	1.92	1.72	1.53	1.34	1.16
Pressure drop in the heat exchanger [kPa]	13	10	8	6	5

Parameters	HC 70-3S-3 stage 3400 m3/h				
Supply/return water temperature [°C]	50/30				
Dry bulb air inlet temperature [°C]	0	5	10	15	20
Heating capacity [kW]	26.7	22.4	18.3	14.1	9.94
Dry bulb air outlet temperature [°C]	21.9	23.7	25.5	27.1	28.7
Water flow [m³/h]	1.16	0.97	0.79	0.61	0.43
Pressure drop in the heat exchanger [kPa]	5	4	3	2	1

Parameters	HC 70-3S-3 stage 3400 m3/h				
Supply/return water temperature [°C]	40/30				
Dry bulb air inlet temperature [°C]	0	5	10	15	20
Heating capacity [kW]	25.1	20.9	16.8	12.7	8.78
Dry bulb air outlet temperature [°C]	20.5	22.4	24.2	26.0	27.7
Water flow [m³/h]	2.17	1.81	1.45	1.1	0.76
Pressure drop in the heat exchanger [kPa]	17	12	8	5	2

Parameters	HC 80-3S-3 stage 4200 m3/h				
Supply/return water temperature [°C]	120/90				
Dry bulb air inlet temperature [°C]	0	5	10	15	20
Heating capacity [kW]	91.5	86.2	81.1	75.9	70.8
Dry bulb air outlet temperature [°C]	61.2	63.3	65.5	67.7	69.8
Water flow [m³/h]	2.70	2.55	2.39	2.24	2.09
Pressure drop in the heat exchanger [kPa]	23	20	18	16	14

Parameters	HC 80-3S-3 stage 4200 m3/h				
Supply/return water temperature [°C]	90/70				
Dry bulb air inlet temperature [°C]	0	5	10	15	20
Heating capacity [kW]	69.2	64.1	59.1	54.1	49.3
Dry bulb air outlet temperature [°C]	46.2	48.4	50.5	52.6	54.6
Water flow [m³/h]	3.05	2.83	2.60	2.39	2.17
Pressure drop in the heat exchanger [kPa]	29	25	22	18	15

Parameters	HC 80-3S-3 stage 4200 m3/h				
Supply/return water temperature [°C]	80/60				
Dry bulb air inlet temperature [°C]	0	5	10	15	20
Heating capacity [kW]	59.6	54.6	49.6	44.8	40.0
Dry bulb air outlet temperature [°C]	39.8	41.9	44.0	46.1	48.1
Water flow [m³/h]	2.62	2.40	2.18	1.97	1.76
Pressure drop in the heat exchanger [kPa]	22	19	16	13	11

Parameters	HC 80-3S-3 stage 4200 m3/h				
Supply/return water temperature [°C]	70/50				
Dry bulb air inlet temperature [°C]	0	5	10	15	20
Heating capacity [kW]	49.9	45.0	40.1	35.3	30.6
Dry bulb air outlet temperature [°C]	33.3	35.4	37.5	39.5	41.5
Water flow [m³/h]	2.18	1.97	1.75	1.54	1.34
Pressure drop in the heat exchanger [kPa]	16	13	11	8	6

Parameters	HC 80-3S-3 stage 4200 m3/h				
Supply/return water temperature [°C]	50/30				
Dry bulb air inlet temperature [°C]	0	5	10	15	20
Heating capacity [kW]	30.3	25.5	20.7	16.0	11.2
Dry bulb air outlet temperature [°C]	20.2	22.2	24.2	26.1	27.9
Water flow [m³/h]	1.31	1.11	0.90	0.70	0.49
Pressure drop in the heat exchanger [kPa]	6	5	3	2	1

Parameters	HC 80-3S-3 stage 4200 m3/h				
Supply/return water temperature [°C]	40/30				
Dry bulb air inlet temperature [°C]	0	5	10	15	20
Heating capacity [kW]	28.6	23.8	19.2	14.6	10.0
Dry bulb air outlet temperature [°C]	19.1	21.1	23.1	25.1	27.0
Water flow [m³/h]	2.48	2.07	1.66	1.26	0.87
Pressure drop in the heat exchanger [kPa]	22	15	10	6	3

### 3. ASSEMBLY

#### 3.1. GENERAL PRINCIPLES

During installation, ensure a free air flow to the device and do not restrict the air stream supply. The figures below show the recommended distances between the heater and building partitions:

a) in case of wall mounting

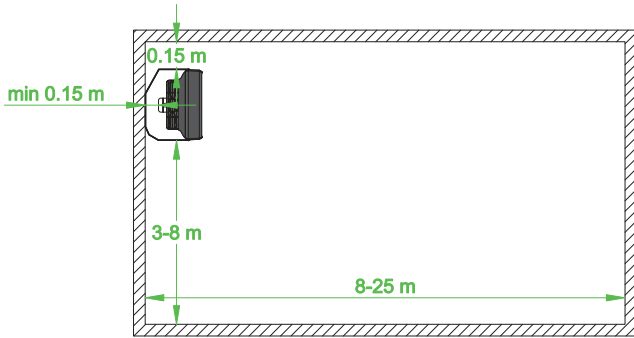

b) in case of ceiling mounting

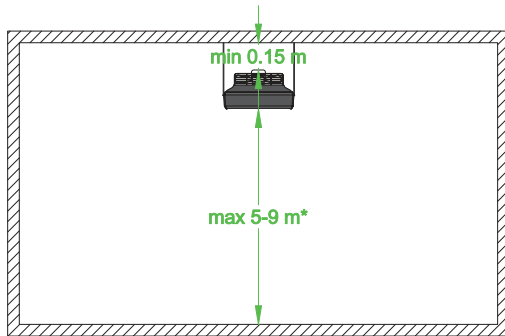

\* the maximum vertical range depends on the model

In case of higher heat demand, more units can be installed in the room. In order to ensure proper air flow, it is necessary to maintain the recommended distances between the heaters, as shown in the following figure.

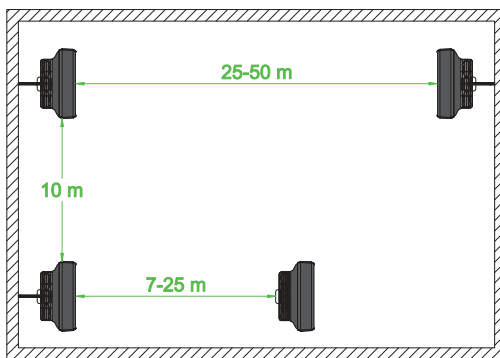

#### 3.2. ROTATING MOUNTING BRACKET

The Reventon Group HC series devices can be assembled using a rotating mounting bracket. It enables the heaters installation on the wall or ceiling, depending on the required optimal direction of airflow.

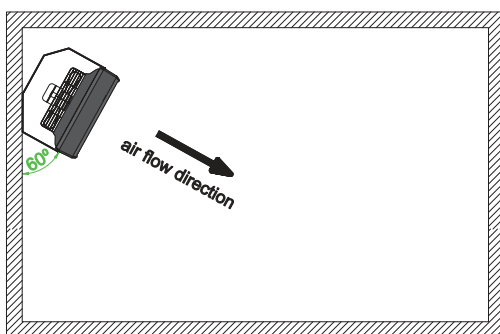

### 4. INSTALLATION INSTRUCTIONS

#### 4.1. CONNECTION OF THE DEVICE TO THE HYDAULIC SYSTEM

- pipes should be connected as indicated on the heater (supply from below, return from above)

- connecting the device to the hydraulic installation, do remember to hold the connectors by pipes spanner

Not keeping to the recommendation may cause the damages of the heating coil.

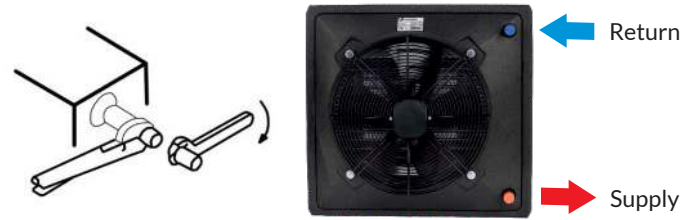

- it is recommended to use filter on the water supply pipe

- it is recommended to use the following valves:

- vent valve in the highest place on the hydraulic installation
- cut off valve on the supply and return pipes of the device

- installation has to be secured against excessive increase of pressure

- it is recommended to check the leak tightness of the hydraulic system before plugging the electric supply

#### 4.2. CONNECTION OF THE DEVICE TO THE ELECTRICAL SYSTEM

- all works concerning electrical installation should be made by the qualified personnel (who possess required authorizations to install electrical equipment), based on wiring schematic diagrams (see 7)

- the electrical installation of the building shall have a residual current device

- it is recommended to check the electric installation and controls before the first start

### 5. PRECAUTIONS & WARNINGS

The precautions mentioned below must be strictly followed during operation of the device:

- all works concerning electrical installation (disassembly, repair etc.) should be made by the qualified staff, who possess the qualifications due to the domestic and local norms, regarding electrical installations

- before service or exchange of the device it is obligatory to cut off the current supply

- do not limit or cover the inlet and outlet of the device

- do not install, service the device with wet hands or barefoot

- the device should be kept out of reach of children and animals

- the device does not consist of the anti-frost protection - the temperature in the room, where device is installed, should not go below 0°C; if such situation could take place empty the device out of water

- after the turn off, the elements of device may be warm

- after operating time of the device, please utilize it concerning the local norms and regulations

- it is recommended to clean the device periodically (at least twice a year):

- heating coil blow with compressed air
- fan casing and blades clean from dirt

- failure to comply with cleaning obligations may have a negative effect on technical parameters of the device and lead to loss of warranty

- if the device is not used for a longer time disconnect the power supply

- air stators of the device have to be open in at least 30% before first start:

- **standard version** - opening of air stators must be done by two hands in parallel



- **version with diffuser 360°** - air stators of diffuser 360° must be done by two hands to the outside



- **version with confuser** - the outlet do not have air stators which must be open

- using diffuser 360° or confuser causes decrease of device airflow of around 10% and consequently reduction of its heating capacity of about 5%

## 6. CONTROLS

Usage of automatic control dedicated to the air water heaters of Reventon Group gives great possibilities of adjusting the efficiency of the heater in different, depending on needs, degree of its operation automation. We can offer the following:

### 3-stage speed controller with thermostat HC-3S

is used to regulate devices equipped with 3-stage fans. It has a 3-stage speed control and built-in thermostat switches the device of automatically when the preset temperature is reached. In addition, the unit controls the operation of the actuators installed on the control valve.



Voltage/ Frequency: 230 V AC / 50 – 60 Hz  
 Maximum current output: 3 A  
 Temperature range: 10°C - 30°C  
 Operating mode: continuous or thermostatic  
 Control accuracy: < 1°C  
 Dimensions: 130 x 85 x 40 mm  
 Weight: 210 g  
 Degree of casing's protection: IP 30

### Programmable controller HMI

is used to regulate devices equipped with 3-stage fans. It is an advanced controller with many functions i. a. operation in heating, cooling or mixed mode, programmable mode, valve control, automatic selection of the fan speed. Together with the controller an external sensor is provided, which allows to read the temperature in the required place, even remote from the controller. In addition, the device can be integrated with the BMS building control system (using the MODBUS communication protocol).



Voltage/ Frequency: 230 V AC / 50 – 60 Hz  
 Maximum current: 5 A  
 Operating temperature range: 0 - 45°C  
 Regulation range: 5°C - 35°C  
 Regulation accuracy: ± 0.5°C  
 External temperature sensor: NTC 10K  
 Communication: RS485  
 Dimensions: 86 x 86 x 13.3 mm  
 Weight: 270 g  
 Degree of protection (housing): IP 20  
 Degree of protection (external sensor): IP 68

### Fanspeed controller HC

designed to change the single-phase fan's speed voltage controlled in industrial supply and heating systems. It is available in several versions. The selection of the appropriate model depends on the number of the devices that have to be connected to the to one regulator – the total intensity of the connected devices cannot exceed the maximum current flow of the regulator.



5 control levels: 80-105-135-170-230 V\*  
 Voltage/ Frequency: 230 V AC / 50 – 60 Hz  
 Maximum current output (depending on model):  
 1.2 A, 3 A, 5 A, 7 A, 14 A  
 Protection: thermal switch  
 Weight (depending on model):  
 1.45 kg, 2.5 kg, 4.5 kg, 5.5 kg or 10.5 kg  
 Degree of protection: IP 54

\* regulation for 3 A regulator: 70-85-105-145-230 V

### Two-way valve with actuator 3/4"

is used to automatically regulate the flow of the heating medium.



Voltage / Frequency: 230 V AC / 50 – 60 Hz  
 Power consumption: 2 VA  
 Kvs coefficient: 6.3 m³/h  
 Stroke: 3 mm  
 Operating condition of actuator: -5°C - 60°C  
 Running time: 3 - 5 min  
 Degree of protection: IP 54

### Three-way valve with actuator HC 3/4"

is used to automatically regulate the flow of the heating medium.



Power supply/ Frequency: 230 V AC / 50 – 60 Hz  
 Power consumption: 7 VA  
 Kvs coefficient: 6.5 m³/h  
 Operating condition of actuator: 0 - 60°C  
 Running time (motor): 18 s  
 Running time (return spring): 5 s  
 Degree of protection: IP 20

### Relay Module RM-16A

allows to connect a receiver with higher current consumption than permissible current load of connected regulator.



Power supply/ Frequency : 230 V AC / 50 – 60 Hz  
 Maximum rated current: 16 A  
 Input: NO/COM  
 Input: SL Connection of a regulator with the voltage relay 230 V  
 Dimension: 47 x 47 x 20 mm

### Manual thermostat HC

controls operation of the heater. Switches the unit off automatically when the set temperature is reached.



Power supply/ Frequency: 230 V AC / 50 – 60 Hz  
 Maximum rated current: 3 A  
 Operating temperature: 0 - 40°C  
 Temperature control range: 10 - 30°C  
 Control accuracy: < 1°C  
 Degree of casing's protection: IP 30

COOPERATION OF CONTROLLERS WITH EQUIPEMENT

Model	HC3S	HMI	HC 1.2 A	HC 3 A	HC 5 A	HC 7 A	HC 14 A	RM- 16 A
HC20-3S	3	5	1	3	5	8	16	19
HC30-3S	3	5	1	3	5	8	16	19
HC35-3S	3	5	1	3	5	8	16	19
HC45-3S	3	5	1	3	5	8	16	19
HC50-3S	1	2	-	-	-	-	-	7
HC70-3S	2	4	1	2	4	6	12	14
HC80-3S	1	2	-	-	-	-	-	7

7. CONNECTION SCHEMES

7.1 MODELS FOR HC 20-3S, HC 30-3S, HC 35-3S, HC 45-3S, HC 50-3S, HC 80-3S

LEGEND:

1. Power
2. Main switch, overcurrent circuit breaker\*
3. Air water heater HC-3S
4. 3-stage speed controllers with thermostat
  - A-work in continuous mode
  - B-operation in thermostatic mode
5. Two-way valve with actuator HC 3/4 "
6. Fan speed controller HC\*\*
7. Manual thermostat HC
8. Programmable controller HMI
9. Relay module RM-16A
10. External temperature sensor

\* main switch and safety fuses are not included in the set

\*\* schemes with the fan speed controller HC apply to the following devices: HC 20-3S, HC 30-3S, HC 35-3S, HC 45-3S, HC 70-3S

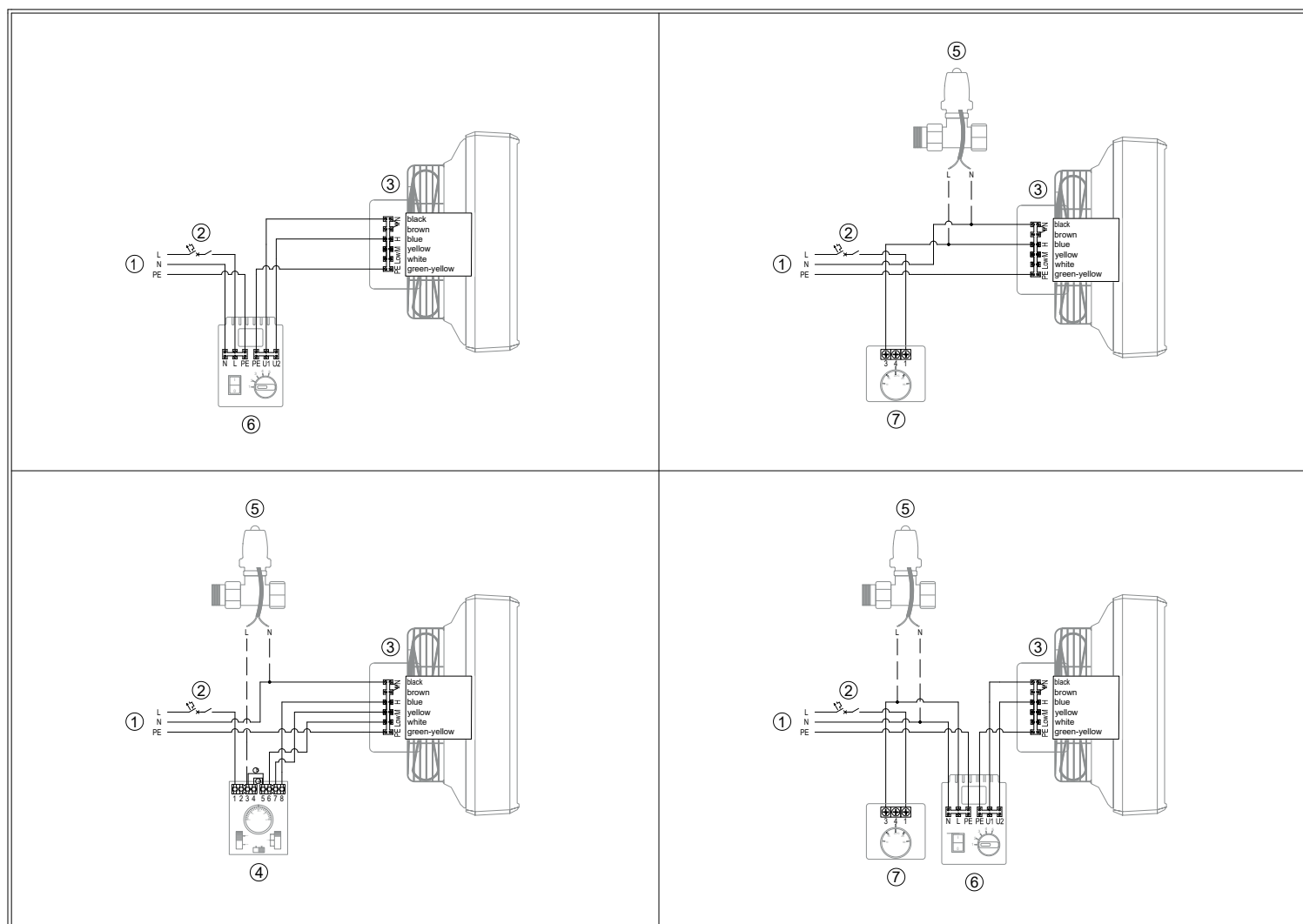



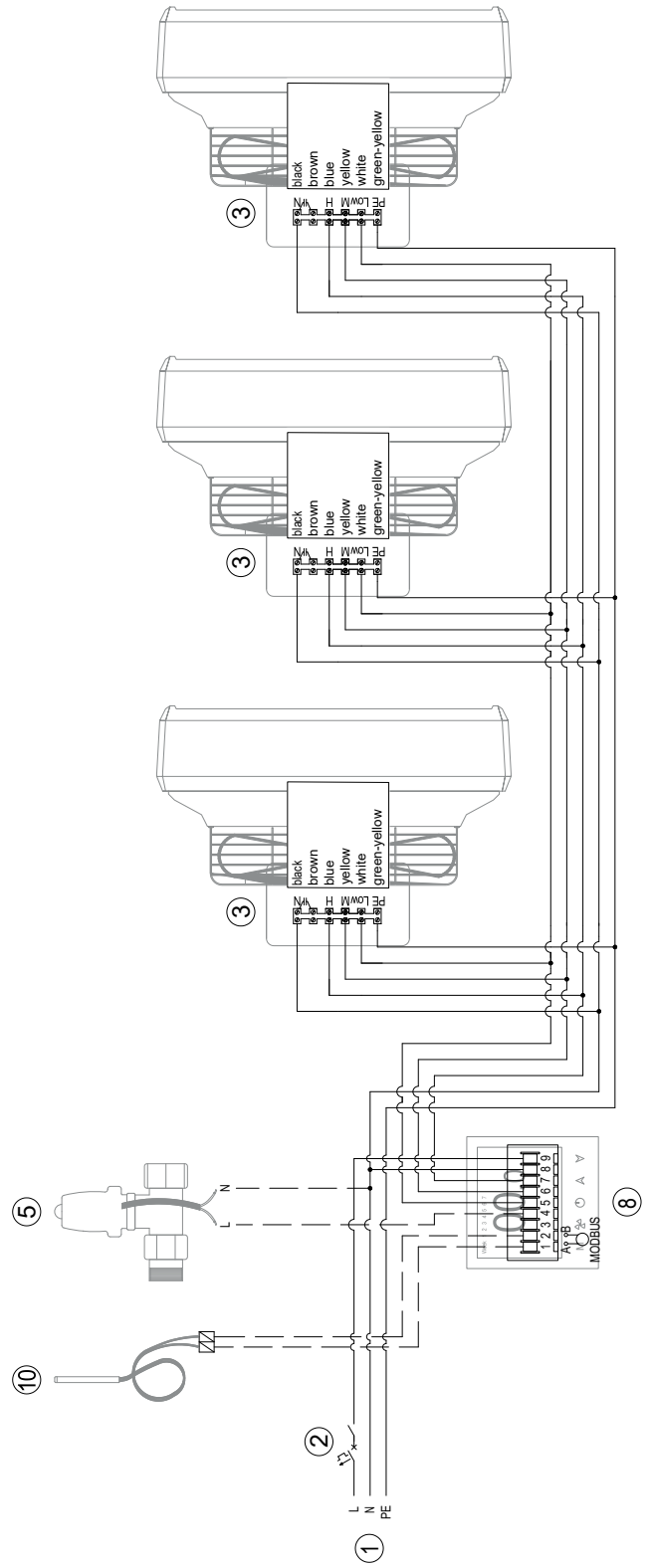
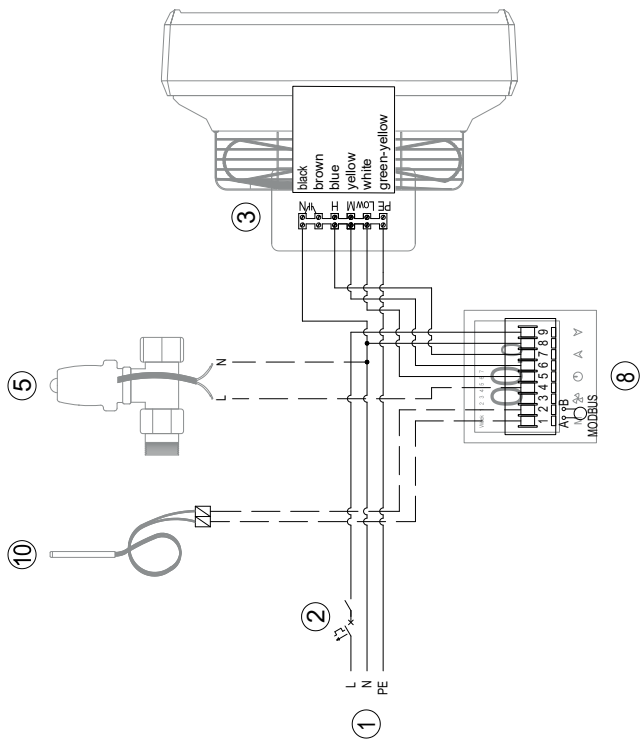

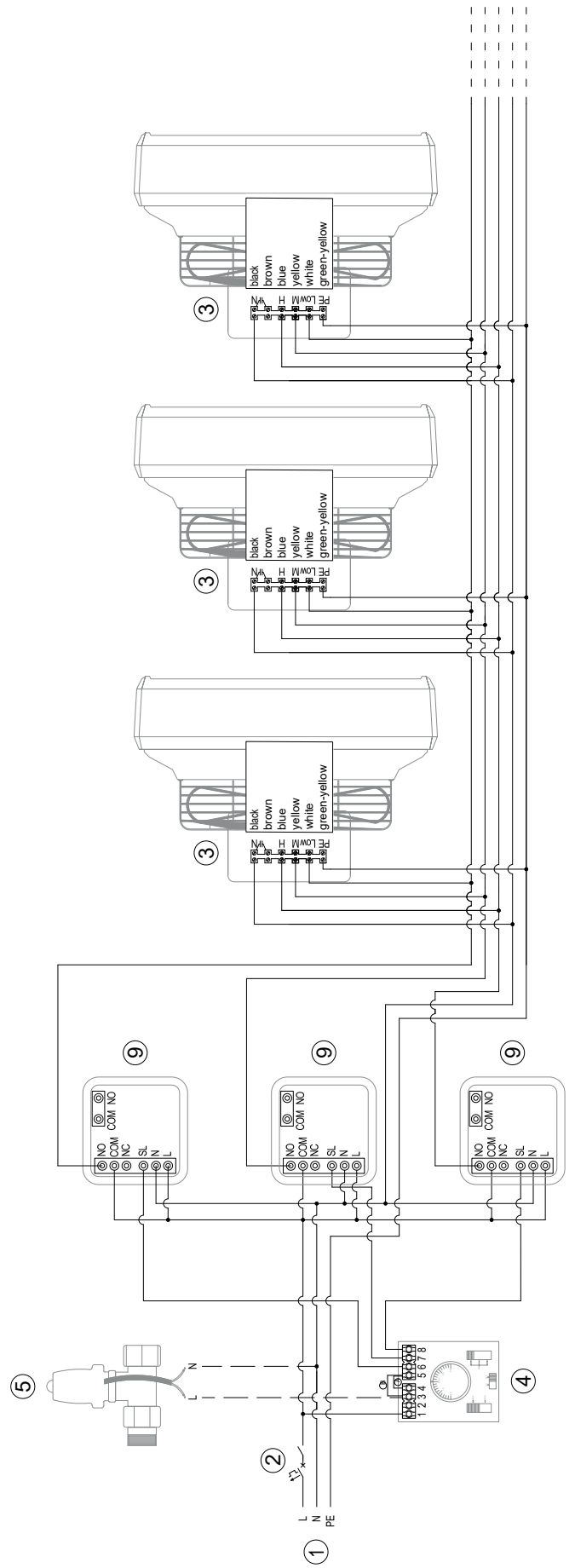
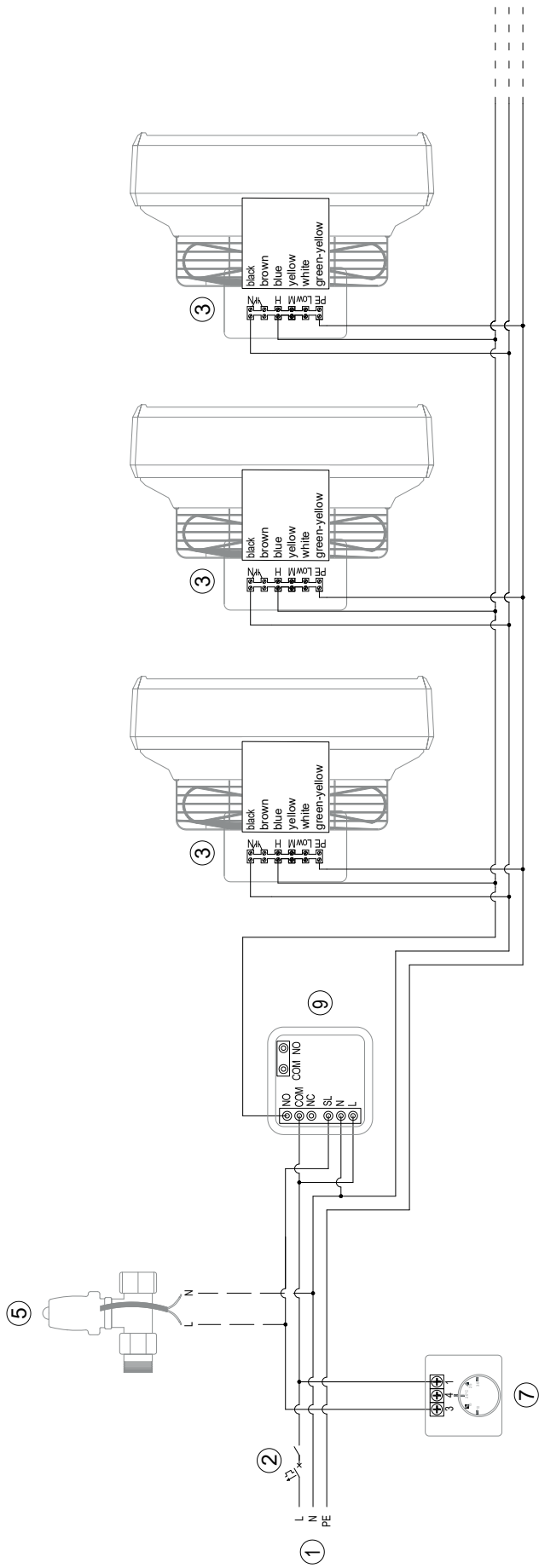

## 7.2 MODEL FOR HC 70-3S

### LEGEND:

1. Power
2. Main switch, overcurrent circuit breaker\*
3. Air water heater HC-3S
4. 3-stage speed controllers with thermostat
  - A-work in continuous mode
  - B-operation in thermostatic mode
5. Two-way valve with actuator HC 3/4 "
6. Fan speed controller HC\*\*
7. Manual thermostat HC
8. Programmable controller HMI
9. Relay module RM-16A
10. External temperature sensor

\* main switch and safety fuses are not included in the set

\*\* schemes with the fan speed controller HC apply to the following devices: HC 20-3S, HC 30-3S, HC 35-3S, HC 45-3S, HC 70-3S

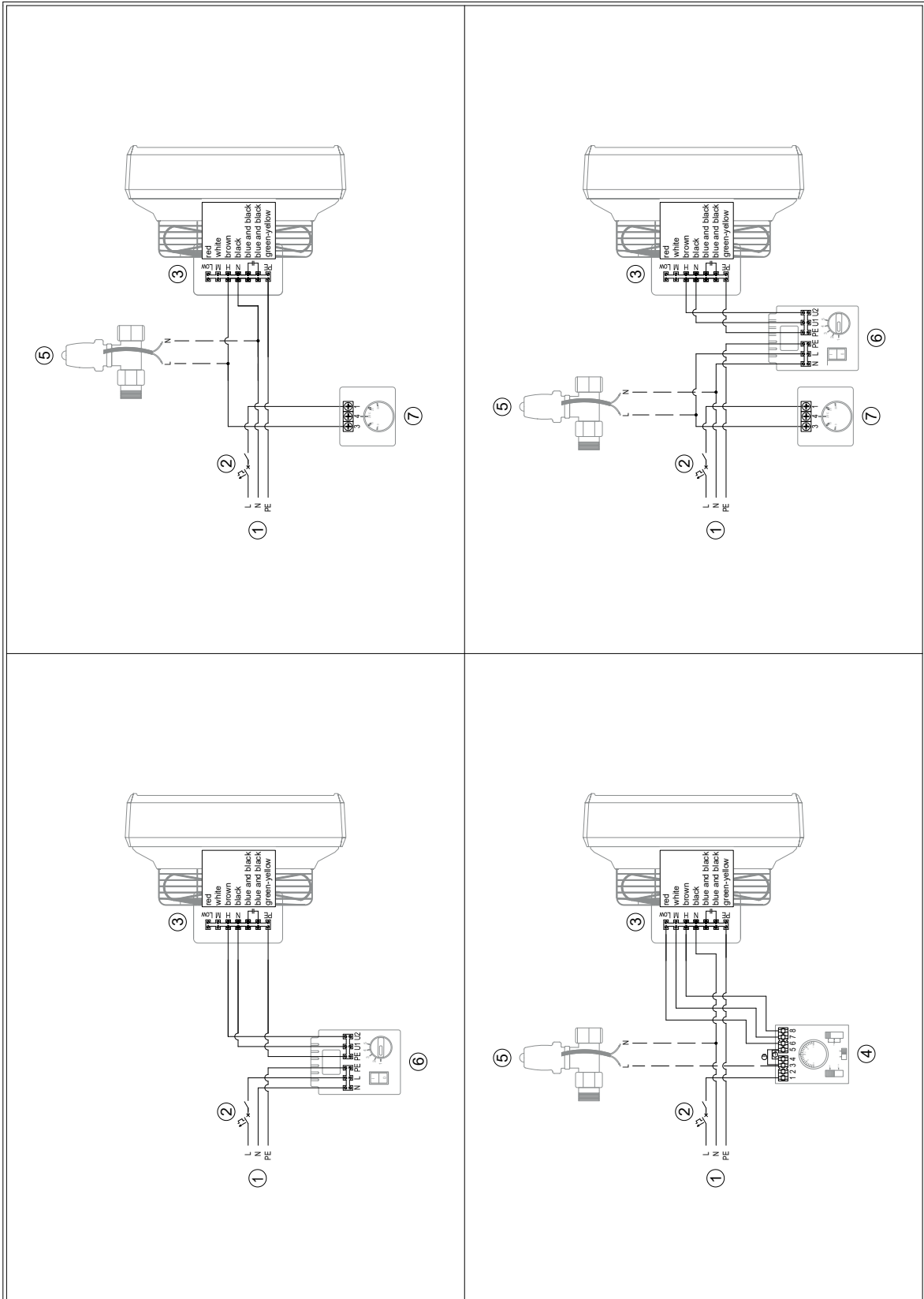

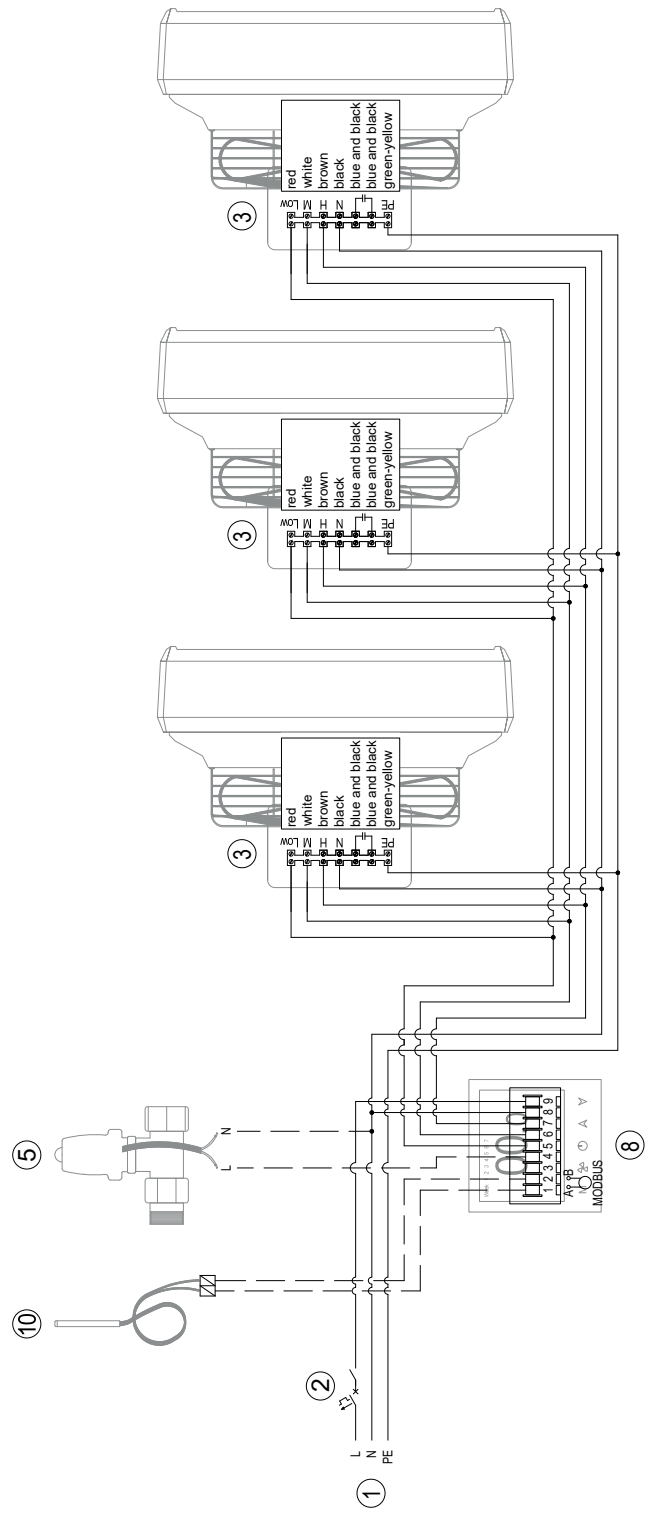
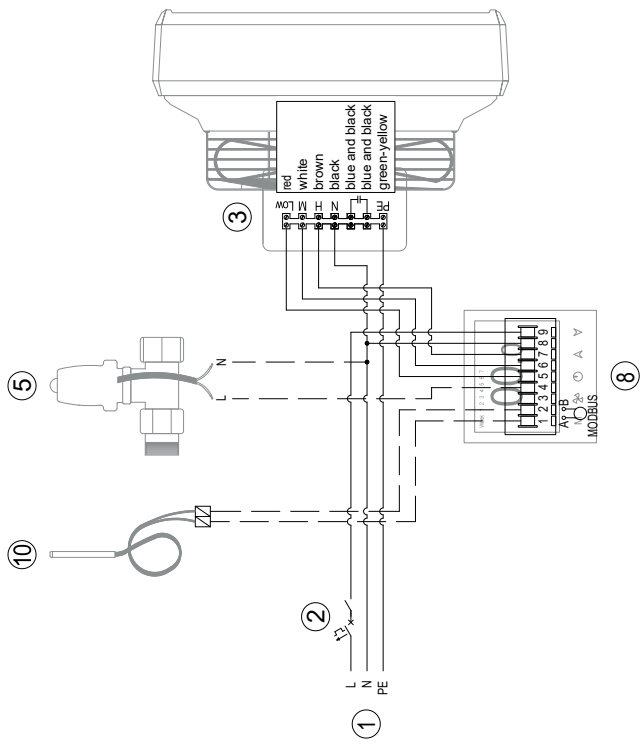

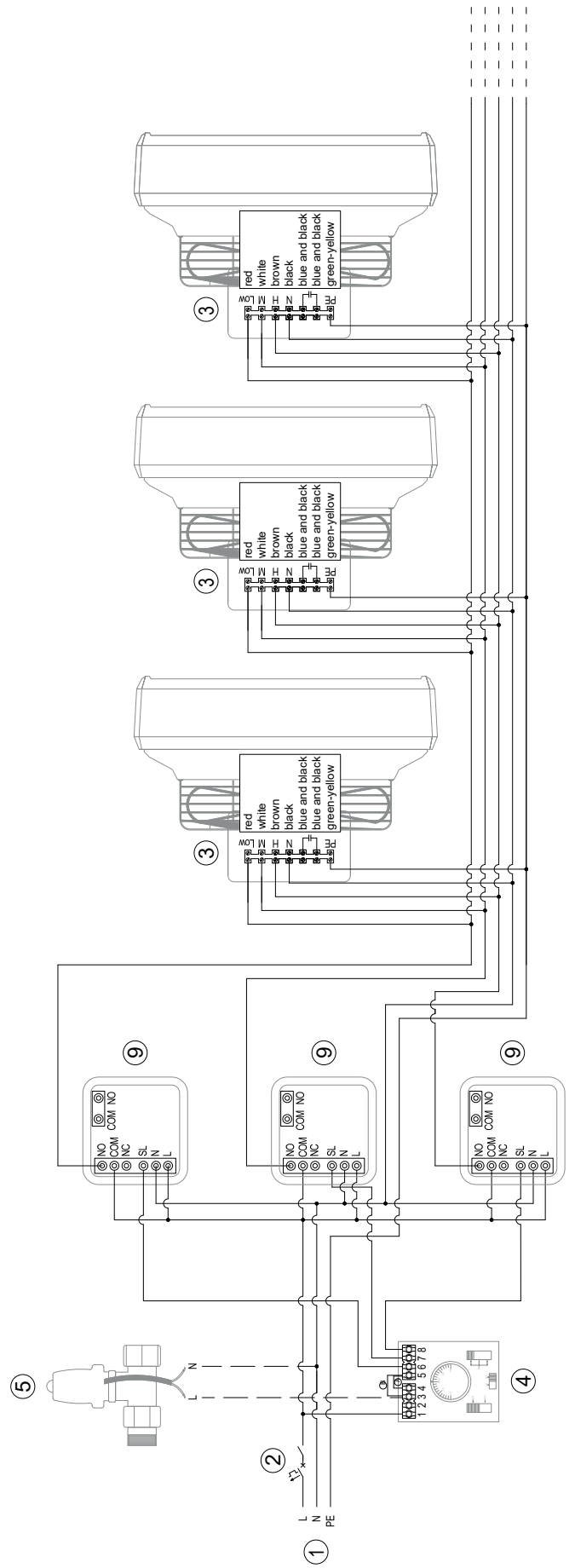
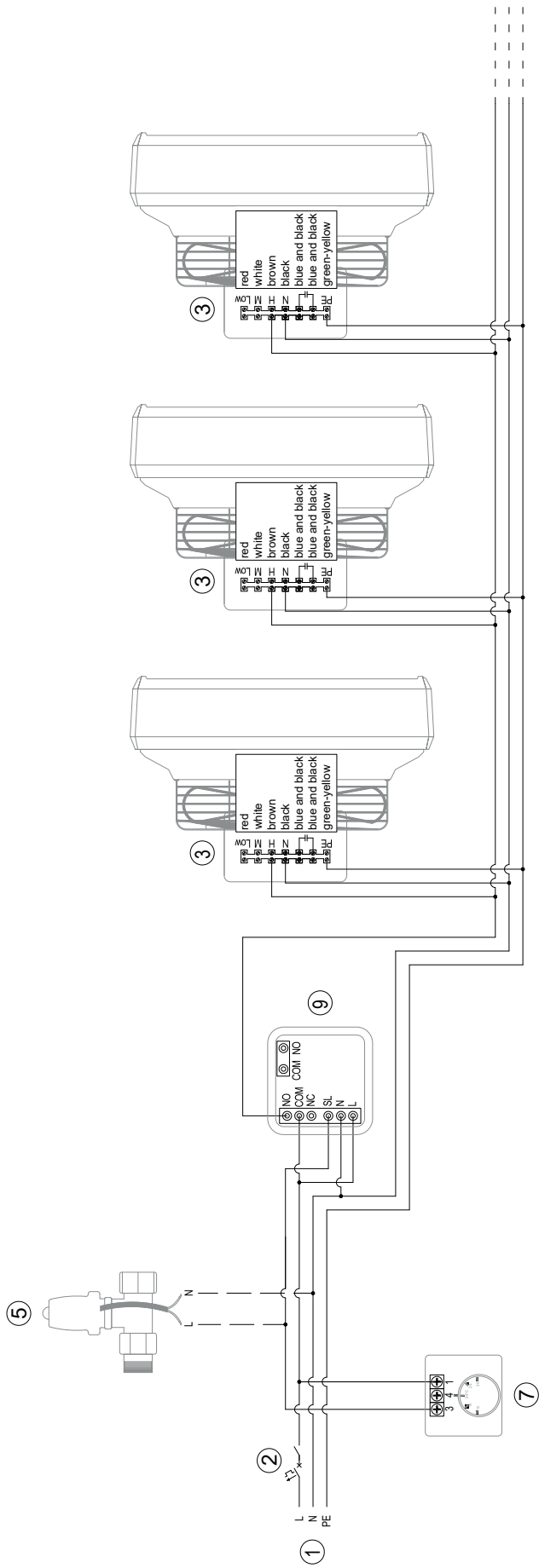

## 8. WARRANTY TERMS

I. The company Reventon Group Sp. z o. o. [Ltd.], hereinafter referred to as the guarantor, provides 24-month warranty protection period for the following devices:

- air water heater HC 20-3S
- air water heater HC 30-3S
- air water heater HC 35-3S
- air water heater HC 45-3S
- air water heater HC 50-3S
- air water heater HC 70-3S
- air water heater HC 80-3S

II. The warranty protection is valid from the purchasing date by end user (i.e. the issue date of invoice) but not longer than 30 months from leaving the warehouse of Reventon Group Sp. z o. o. [Ltd.].

III. The warranty claim should be reported via the complaint form on the website (<https://reventongroup.eu/en/complaints>). The scan or the photo of the fulfilled Warranty Card and the purchase invoice must be attached to the form. The Warranty Card is not required in case of accessories.

IV. The guarantor is committed to consider the claim within 14 working days since the date of reporting (i. e. the day of receipt of the correctly fulfilled warranty form).

V. In exceptional cases, the guarantor reserves the right to extend the time for consideration of the request, especially if the defect is not permanent one and its determination requires a deeper analysis. The extension must be notified by the guarantor before the end of the 14th working day.

VI. Under the warranty, the guarantor provides a repairment, replacement (the device or its component) or refund for the defective item within a specified time.

VII. In the case of replacement of a device component, the warranty protection of the whole unit is not prolonged.

VIII. The guarantor does not cover the costs of disassembly and eventual reassembly of the complaint device.

IX. The guarantor may decide to bring the defective device or its component to the service of Reventon Group Sp. z o. o. [Ltd.]. In such case the transport of the item is organised and paid by the guarantor. The responsibility of the device's owner is to prepare the item for the shipment - the device must be packed in a way which protects it against transport damages and the dimensions and weight of the package must not exceed 660 x 650 x 400 mm and 30 kg respectively. In the case of elements which cannot be packed in this way, the method of shipment must be agreed and approved by Reventon Group Sp. z o. o. [Ltd.]. In the case of sending a non-standard package without agreement of the service of Reventon Group Sp. z o. o. [Ltd.], the guarantor reserves the right to charge the owner of device with all additional transport costs.

X. In the case of arrival of the authorized service of the guarantor or an installer to fix the complaint item, the customer must ensure them seamless access to the device and all required media like electricity, water, lighting etc free of charge

XI. The warranty protection does not cover the parts of the device subject to the normal usage and the following cases:

- a) mechanical damage of the product
- b) defects and damages through:
  - improper storage or transport
  - improper or non-compliant use and maintenance (i. e. inconsistent with the manual)
  - using the device in the improper conditions (too high humidity, too high or too low temperature, impact of the surrounding, sun etc.)
  - unauthorized (i. e. by the user or other unauthorized persons) repairs, modifications or construction changes
  - connecting equipment inconsistent with the technical documentation
  - connecting additional equipment, which is not recommended by the guarantor
  - improper power supply
  - random events (like fire, flood, storm etc.)
- c) elements which wear and tear such as discolour of the housing

If there is any of the above, the claimant will be charged for transport and / or repairs.

XII. During collection of the device, the item must be checked exactly by the receiver to exclude transport damages. If any of them is observed, the damage report in presence of the product deliverer have to be filled - such report is the basement for the warranty claim. The damage report must be provided by the product deliverer.

XIII. The guarantor does not take the responsibility for potential losses and damages related to the downtime of the device during its failure and the complaint considering time.

XIV. Any changes in the Warranty Terms, improper use of the product as well as traces of self repairing (beyond the guarantor service) or alterations cause, the warranty become invalid.

XV. These Warranty Terms do not exclude or limit any rights arising from the pledge.

XVI. Not following to any of the warranty regulations makes the protection invalid.

XVII. All correspondence should be sent to the following address: Reventon Group Sp. z o. o. [Ltd.], 556 Wyzwolenia Street, 43 340 Kozy, Poland or email address: [serwis@reventongroup.eu](mailto:serwis@reventongroup.eu).

## Warranty Card

1 - Model and serial number* or product code	2 - Address and place of assembly
3 - Date of connection to: Heating/cooling installation (if applicable)	4 - Stamp and signature of installer:
Ventilation installation (if applicable)	
Electrical installation (if applicable)	

\* serial numer is required only for water heaters HC-3S, HC-EC and FARMER HCF series and recovery units INSPIRO, INSPIRO BASIC and VERTIC series



**reventon**  
INDUSTRIAL SOLUTIONS

Reventon Group Sp. z o.o. [Ltd.], 556 Wyzwolenia Street, 43-340 Kozy, Poland, [www.reventongroup.eu](http://www.reventongroup.eu)