

reventon
INDUSTRIAL SOLUTIONS

Technical datasheet

AXIAL FAN FR SERIES



- 1. INTRODUCTION
 - 1.1 GENERAL INFORMATION
 - 1.2 STORAGE AND TRANSPORT
 - 1.3 PACKAGE CONTENT
 - 1.4 APPLICATION
- 2. DEVICE CHARACTERISTIC
 - 2.1 CONSTRUCTION AND PRINCIPLE OF OPERATION
 - 2.2 DIMENSIONS
 - 2.3 TECHNICAL DATA
 - 2.4 WORKING CHARACTERISTICS
- 3. ASSEMBLY
 - 3.1 GENERAL PRINCIPLES
- 4. INSTALLATION
 - 4.1 CONNECTION TO ELECTRICAL INSTALLATION
- 5. EXPLOITATION
 - 5.1 EXPLOITATION PRINCIPLES
- 6. CONTROLS
- 7. WIRING DIAGRAMS
- 8. WARRANTY TERMS

1. INTRODUCTION

Thank you very much for purchasing the axial fan FR series. Please read and keep this manual for future reference of users and operators.

1.1 GENERAL INFORMATION

The owner and the user of unit Reventon brand should read carefully this documentation and follow included guidelines. In case of any doubts regarding the content, please reach out directly to the importer of device i. e. the company Reventon Group Sp. z o. o. [Ltd.]. The contact data are given at the section 8 (subsection XVII).

 The key recommendations from safety point of view are marked with the warning triangle (like the one on the left). It enables quick and easy localization of these recommendations and remind of them before interference with the unit. For the same reason, the requirements for periodic inspection and maintenance of the device, are marked with the wrench symbol (like the one on the left).

 During installation, usage or maintenance of the unit, all local safety requirements must be respected.

The owner and each user of unit must be familiar with the Warranty Terms included in the section 8 of this instruction and follow its guidelines. In case of any doubts regarding warranty points, please reach out immediately to the company Reventon Group Sp. z o. o. [Ltd.] before taking any action.

This documentation was developed by the company Reventon Group Sp. z o. o. [Ltd.] - all rights reserved.

The company Reventon Group Sp. z o. o. [Ltd.] reserves the rights to make changes in the technical documentation without previous notice of the user.

1.2 STORAGE AND TRANSPORT

The fan must be stored and transported on an appropriate pallet, in ambient temperature ranging from -30°C to 60°C and relative humidity ≤ 90%.

During collection of the unit, please check the device exactly to exclude any transport damages. If any is observed, the damage report in presence of the product deliverer must be filled. Such report is the basement for the warranty claim. The damage report must be provided by the product deliverer.

1.3 PACKAGE CONTENT

- axial fan FR
- technical documentation including Warranty Card

1.4 APPLICATION

The axial fan FR series, depending on the version, can be used as:

- a fan for cooling, heating or ventilation devices (subseries FR-BG and FR-SG)
- a wall-mounted supply or exhaust fan for buildings like production and storage halls, workshops (subseries FR-BS)
- an element of simple ventilation system (subseries FR-BC)

Irrespective of the subseries, the device is designed for internal usage and cannot be used in contaminated environments with air containing flammable or explosive substances, chemicals, sticky substances, fibrous materials or soot and oil particles. The axial fan cannot be also used in places, where it would be exposed to too high humid (relative humidity higher than 90%) or direct contact with water or dust, exceeding the permissible contact due to the protection degree IP.

2. DEVICE CHARACTERISTIC

2.1 CONSTRUCTION AND PRINCIPLE OF OPERATION

Housing: made of powder coated steel. Depending on the version, it can be the protective grid, the square housing that facilitates direct wall mounting or the duct that allows integration of the fan with the ventilation system. The shapes and dimensions of the housings of individual subseries are shown on the drawings in subsection 2.2.

Axial fan: the fan impeller is made of powder coated steel. The axial fan provides a relatively large airflow, but its efficiency quickly decreases with increasing of flow resistances - for this reason, it is not suitable to use the fan in complex ventilation systems. The airflow direction for particular subseries is marked with the arrow in point 2.2. The fan has a single-phase motor with IP 54 protection.

2.2 DIMENSIONS

FR-BG

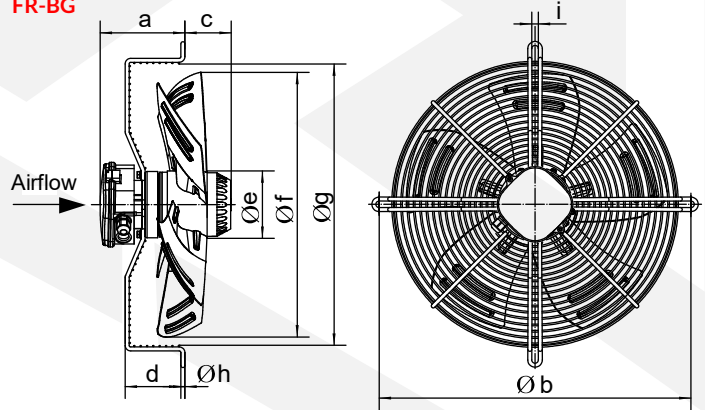

	FR-250-BG	FR-300-BG	FR-350-BG	FR-400-BG	FR-450-BG	FR-500-BG	FR-550-BG	FR-630-BG	FR-710-BG	FR-800-BG
a	116	110	115	125	125	126	136	136	188	185
b	320	360	422	470	522	570	625	750	840	920
c	20	36	54	57	70	53	58	83	65	65
d	56	76	75	90	84	84	94	92.5	165	165
Øe	92	92	102	102	102	137	137	137	180	180
Øf	250-5	300-5	350-5	400-5	450-5	500-5	550-5	630-5	703-5	784-5
Øg	275+5	320+5	370+5	420+5	470+5	520+5	575+5	650+5	770+5	857+5
Øh	4	4	5	6	6	6	6	7.5	10	10
i	7	7	9.5	9.5	9.5	10.5	10.5	10.5	13	13

FR-SG

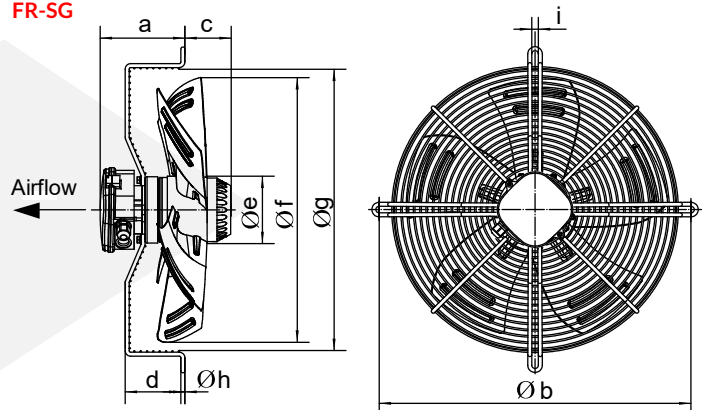

	FR-250-SG	FR-300-SG	FR-350-SG	FR-400-SG	FR-450-SG	FR-500-SG	FR-550-SG	FR-630-SG	FR-710-SG	FR-800-SG
a	116	110	115	125	125	126	136	136	188	185
b	320	360	422	470	522	570	625	750	840	920
c	20	36	54	57	70	53	58	83	65	65
d	56	76	75	90	84	84	94	92.5	165	165
Øe	92	92	102	102	102	137	137	137	180	180
Øf	250-5	300-5	350-5	400-5	450-5	500-5	550-5	630-5	703-5	784-5
Øg	275+5	320+5	370+5	420+5	470+5	520+5	575+5	650+5	770+5	857+5
Øh	4	4	5	6	6	6	6	7.5	10	10
i	7	7	9.5	9.5	9.5	10.5	10.5	10.5	13	13

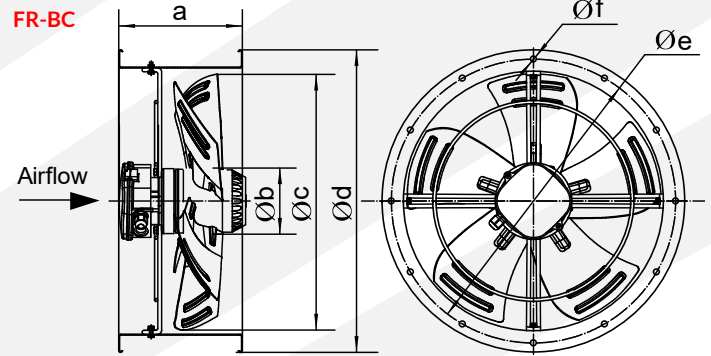
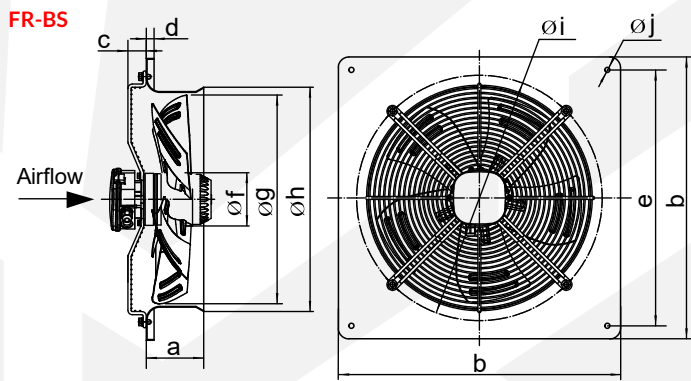

	FR-200-BS	FR-250-BS	FR-300-BS	FR-350-BS	FR-400-BS	FR-450-BS	FR-500-BS	FR-550-BS	FR-630-BS	FR-710-BS	FR-800-BS
a	68	90	90	95	110	110	115	115	125	135	205
b	310	370	430	485	540	575	655	725	805	845	970
c	4	4	4	35	35	35	35	35	35	115	60
d	15	15	15	15	15	15	15	15	15	27	16
e	260	320	380	435	490	535	615	670	750	810	910
Øf	92	92	92	102	102	102	137	137	137	180	180
Øg	200-5	250-5	300-5	350-5	400-5	450-5	500-5	550-5	630-5	703-5	784-5
Øh	210	280	325	380	430	480	530	570	660	718	830
Øi	260	320	380	415	470	520	580	650	730	795	950
j	4x Ø7	4x Ø7	4x Ø7	4x Ø10.5	4x Ø10.5	4x Ø10.5	4x Ø10.5	4x Ø10.5	4x Ø10.5	4x Ø11	4x Ø14.5

	FR-200-BC	FR-250-BC	FR-300-CG	FR-350-BC	FR-400-BC	FR-450-BC	FR-500-BC	FR-550-BC	FR-630-BC
a	180	180	180	180	210	210	250	252	250
Øb	92	92	92	102	102	102	137	137	137
Øc	200-5	250-5	300-5	350-5	400-5	450-5	500-5	550-5	630-5
Ød	250	306	390	424	466	515	567	640	705
Øe	222.5	285	360	395.5	437	489.5	542	606	675.5
Øf	8xØ7	8xØ7	8xØ9.5	8xØ9.5	12xØ9.5	12xØ9.5	12xØ9.5	12xØ10.5	16xØ10

2.3 TECHNICAL DATA

MODEL Product code	FR-250-BG IAFR250BG-1701	FR-300-BG IAFR300BG-1702	FR-350-BG IAFR350BG-1703	FR-400-BG IAF400BG-1704	FR-450-BG IAFR450BG-1705	FR-500-BG IAFR500BG-1706	FR-550-BG IAFR550BG-1707	FR-630-BG IAFR630BG-1708	FR-710-BG IAFR710BG-1709	FR-800-BG IAFR800BG-1710
Maximal airflow [m³/h]	1450	1750	2350	3800	5400	6050	7500	11400	Y 13000 Δ 15000	Y 17500 Δ 20000
Voltage [V]/Frequency [Hz]	230 / 50	230 / 50	230 / 50	230 / 50	230 / 50	230 / 50	230 / 50	230 / 50	400 / 50	400 / 50
Nominal motor current [A]	0.42	0.38	0.58	0.84	1.08	1.35	1.75	2.90	Y 3 x 1.15 Δ 3 x 1.90	Y 3 x 1.65 Δ 3 x 2.85
Nominal motor power [W]	90	75	124	190	240	295	385	660	Y 650 Δ 900	Y 930 Δ 1200
Nominal motor speed [rpm]	2400	1350	1400	1400	1360	1380	1380	1300	Y 730 Δ 900	Y 770 Δ 920
IP protection rating of motor [-]	54	54	54	54	54	54	54	54	54	54
Insulation class [-]	F	F	F	F	F	F	F	F	F	F
Net weight [kg]	2.50	3.00	5.00	6.00	8.00	9.00	11.00	15.00	30.00	35.00
Noise [dB(A)]*	60	62	64	67	69	70	71	74	Y 72 Δ 73	Y 74 Δ 75

* the measurement at the distance of 1 m from the device

MODEL Product code	FR-250-SG IAFR250SG-1711	FR-300-SG IAFR300SG-1712	FR-350-SG IAFR350SG-1713	FR-400-SG IAF400SG-1714	FR-450-SG IAFR450SG-1715	FR-500-SG IAFR500SG-1716	FR-550-SG IAFR550SG-1717	FR-630-SG IAFR630SG-1718	FR-710-SG IAFR710SG-1719	FR-800-SG IAFR800SG-1720
Maximal airflow [m³/h]	1450	1850	2450	3950	5000	6050	7500	11400	Y 13000 Δ 15000	Y 17500 Δ 20000
Voltage [V]/Frequency [Hz]	230 / 50	230 / 50	230 / 50	230 / 50	230 / 50	230 / 50	230 / 50	230 / 50	400 / 50	400 / 50
Nominal motor current [A]	0.42	0.42	0.65	0.82	1.15	1.35	1.75	2.90	Y 3 x 1.15 Δ 3 x 1.90	Y 3 x 1.65 Δ 3 x 2.85
Nominal motor power [W]	90	85	126	180	250	295	385	660	Y 650 Δ 900	Y 930 Δ 1200
Nominal motor speed [rpm]	2400	1380	1420	1380	1350	1380	1380	1300	Y 730 Δ 900	Y 770 Δ 920
IP protection rating of motor [-]	54	54	54	54	54	54	54	54	54	54
Insulation class [-]	F	F	F	F	F	F	F	F	F	F
Net weight [kg]	2.50	3.00	5.00	6.00	8.00	9.00	11.00	15.00	30.00	35.00
Noise [dB(A)]*	60	60	64	67	69	70	71	74	Y 72 Δ 73	Y 74 Δ 75

* the measurement at the distance of 1 m from the device

MODEL Product code	FR-200-BS IAFR200BS-1721	FR-250-BS IAFR250BS-1722	FR-300-BS IAFR300BS-1723	FR-350-BS IAFR350BS-1724	FR-400-BS IAFR400BS-1725	FR-450-BS IAFR450BS-1726	FR-500-BS IAFR500BS-1727	FR-550-BS IAFR550BS-1728	FR-630-BS IAFR630BS-1729	FR-710-BS IAFR710BS-1730	FR-800-BS IAFR800BS-1731
Maximal airflow [m³/h]	780	1450	1550	2450	3950	5000	6050	7500	11400	Y 13000 Δ 15000	Y 17500 Δ 20000
Voltage [V]/Frequency [Hz]	230 / 50	230 / 50	230 / 50	230 / 50	230 / 50	230 / 50	230 / 50	230 / 50	230 / 50	400 / 50	400 / 50
Nominal motor current [A]	0.25	0.42	0.40	0.65	0.82	1.15	1.35	1.75	2.90	Y 3 x 1.15 Δ 3 x 1.90	Y 3 x 1.65 Δ 3 x 2.85
Nominal motor power [W]	55	90	75	126	180	250	295	385	660	Y 650 Δ 900	Y 930 Δ 1200
Nominal motor speed [rpm]	2500	2400	1400	1420	1380	1350	1380	1380	1300	Y 730 Δ 900	Y 770 Δ 920
IP protection rating of motor [-]	54	54	54	54	54	54	54	54	54	54	54
Insulation class [-]	F	F	F	F	F	F	F	F	F	F	F
Net weight [kg]	2.00	3.50	4.00	6.00	7.00	9.00	10.00	13.00	24.00	40.00	40.00
Noise [dB(A)]*	52	60	60	64	67	69	70	71	74	Y 72 Δ 73	Y 74 Δ 75

* the measurement at the distance of 1 m from the device

MODEL Product code	FR-200-BC IAFR200BC-1732	FR-250-BC IAFR250BC-1733	FR-300-BC IAFR300BC-1734	FR-350-BC IAFR350BC-1735	FR-400-BC IAFR400BC-1736	FR-450-BC IAFR450BC-1737	FR-500-BC* IAFR500BC-1738	FR-550-BC IAFR550BC-1739	FR-630-BC IAFR630BC-1740
Maximal airflow [m³/h]	780	1200	1550	2450	3950	5000	7200	7500	11400
Voltage [V]/Frequency [Hz]	230 / 50	230 / 50	230 / 50	230 / 50	230 / 50	230 / 50	230 / 50	230 / 50	230 / 50
Nominal motor current [A]	0.25	0.35	0.40	0.65	0.82	1.15	1.75	1.75	2.90
Nominal motor power [W]	55	80	75	126	180	250	380	385	660
Nominal motor speed [rpm]	2500	2650	1400	1420	1380	1350	1320	1380	1300
IP protection rating of motor [-]	54	54	54	54	54	54	54	54	54
Insulation class [-]	F	F	F	F	F	F	F	F	F
Net weight [kg]	2.00	3.50	5.00	6.00	7.00	9.00	11.00	12.00	17.00
Noise [dB(A)]*	52	60	60	64	67	69	71	71	74

* not compatible with speed controllers like the fan speed controller HC and the thyristor speed controller TRO

** the measurement at the distance of 1 m from the device

2.4 WORKING CHARACTERISTICS

FR-BG

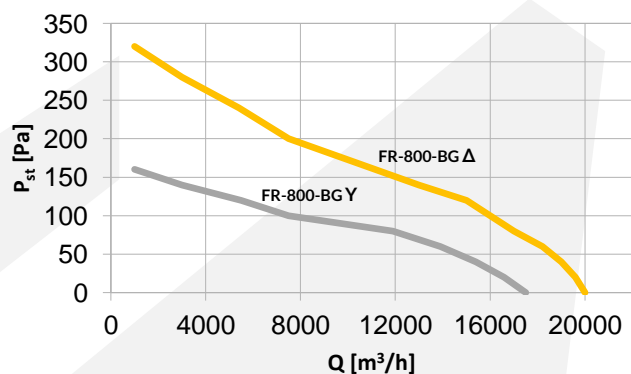
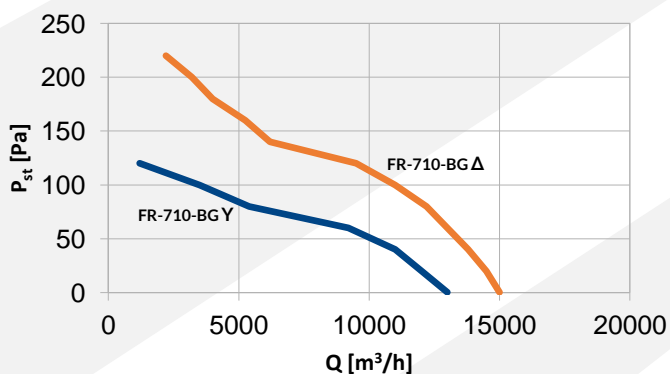
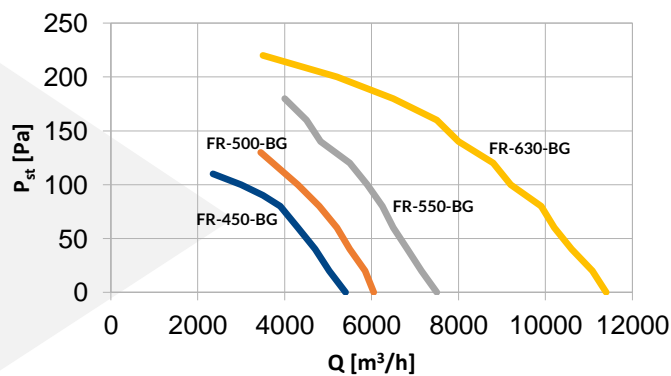
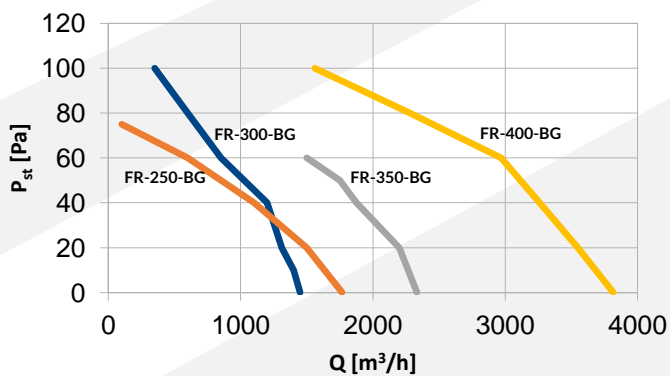

FR-SG

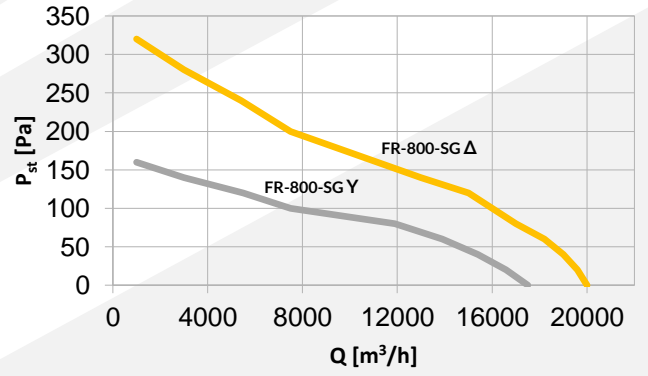
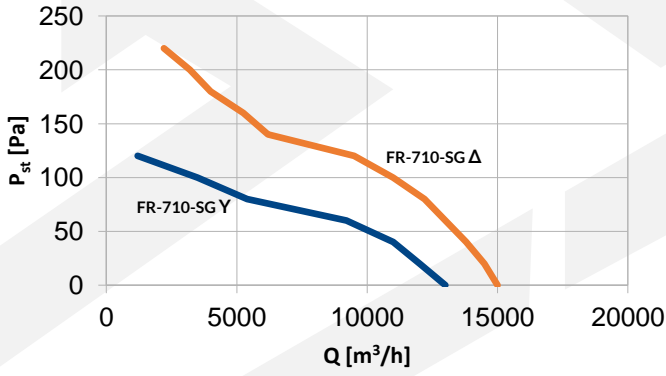
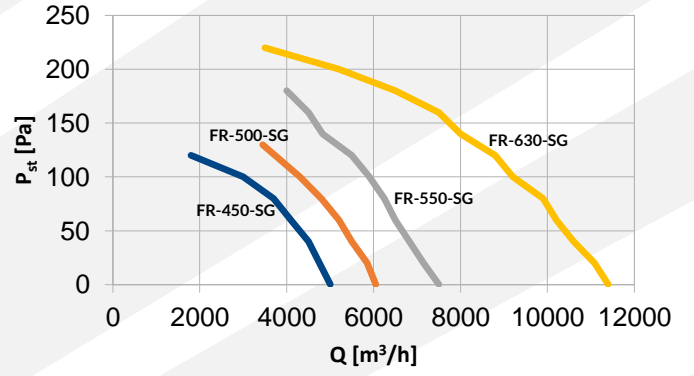
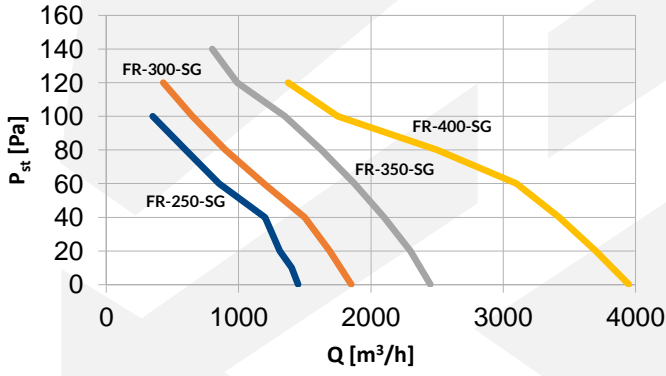

FR-BS

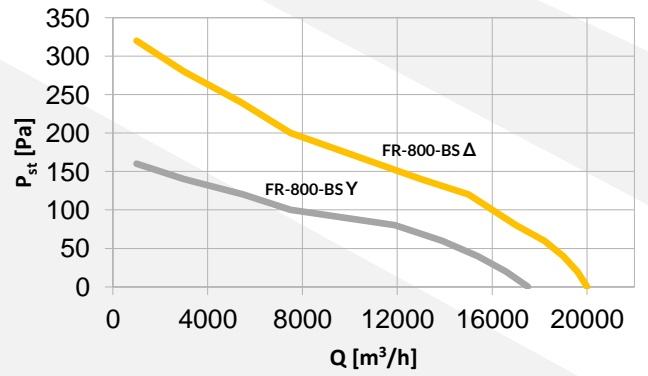
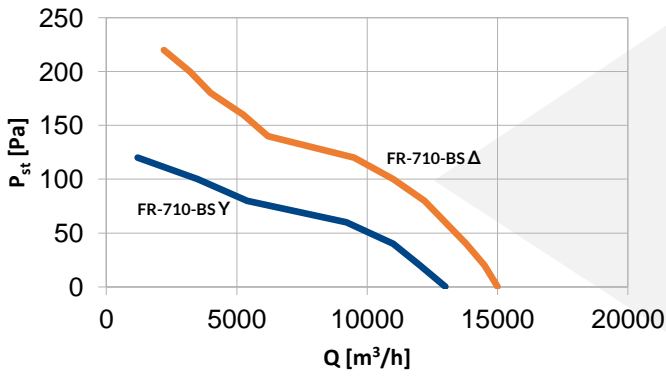
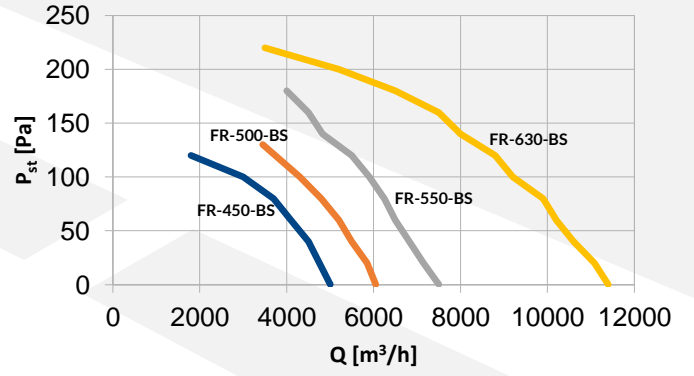
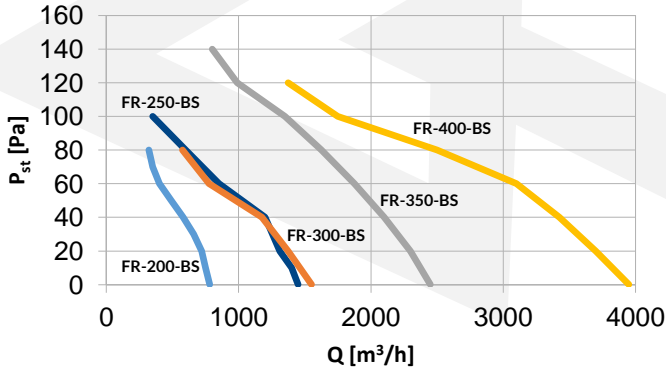

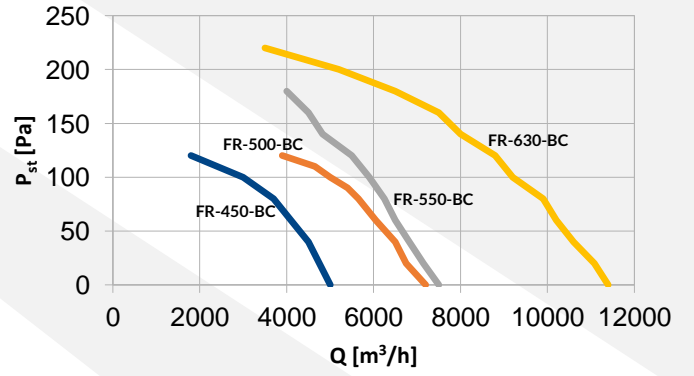
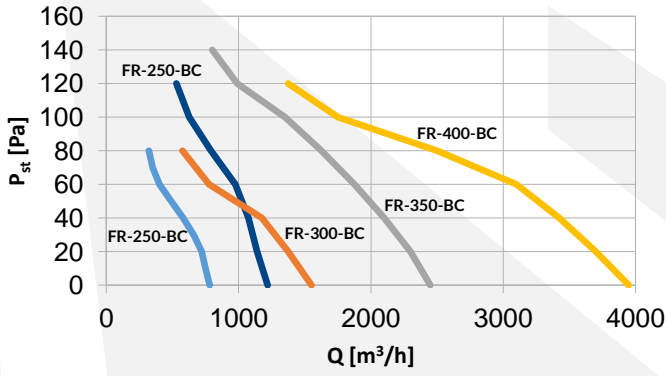

FR-BC



3 ASSEMBLY

3.1 GENERAL PRINCIPLES

 The axial fan should be assembled by people experienced in mounting of such devices and - if local law requires it - with appropriate qualifications.

 It is the responsibility of the assemblers to make the mounting according to the guidelines from this instruction and in accordance with the local regulations in force.

After mounting of the device, the assembler is obliged to fill out the Warranty Card (positions 1 and 2). It is also treated as a guarantee, that the assembly was made in accordance with the requirements. The Warranty Card is included in this manual under the Warranty Terms.

 During mounting, the direction of air flow through the fan must be considered (see the arrow in subsection 2.2).

 Regardless of the application (see section 1.4), axial fan FR series should be installed in a way that prevents direct access to the impeller or it should be protected, e. g. with a protective grid.

If the fan is used as the wall-mounted exhaust fan (see section 1.4), it is recommended to protect the outlet from the outside side with the GS series gravity shutter.

 The axial fan must be mounted using elements with a load capacity appropriate to its weight.

4. INSTALLATION

 Before connecting the unit to a ventilation and an electrical installation, it must be assembled permanently to a suitable partition (according to the recommendations contained in the section 3).

 All installation, repairs and disassembly works, must be performed by qualified persons i. e. having the appropriate qualifications for these works. It is the responsibility of the installer to make the installation according to the guidelines from this instruction and in accordance with the local regulations in force.

After connecting to the electric installation, the installer is obliged to make an entry in the Warranty Card, confirmed by a stamp and signature (positions 3 and 4). It is also treated as a guarantee, that the installation was made in accordance with the requirements of this point 4. The Warranty Card is included in this manual under the Warranty Terms in the section 8.

4.1 CONNECTION TO ELECTRICAL INSTALLATION

 The electrical installation must be carried out in accordance with the state of the art and the local regulations in force.

 The electrical connection to an installation with the electrical parameters according to the section 2.3 should be made in according to the appropriate connection diagram from section 7 (it applies only to fans with supply voltage 230 V).

 The fan FR series with the supply voltage specified as 400 V (see section 2.3), must be connected to the three-phase grid with the appropriate parameters, in accordance with the wiring diagram on the cover of the fan's connection box.

 As the power cable, it is recommended to use a three-core cable with a 1.5 mm² cross-section with earthing.

 The electrical circuit to which the device is connected, should include all safety element required by the law and the ON/OFF switch enabling safe disconnection of the duct fan from the electrical system. These elements are indicated overall as no. 2 on the connection diagrams in the section 7.

 Before the start up, it is required to check the electrical installation in terms of damaged insulation, incorrect connection in the terminals, risk of potential short circuits etc.

5. EXPLOITATION

5.1 EXPLOITATION PRINCIPLES

 The user is obliged to be familiar with this instruction before exploitation of the device.

 Before any interference in the device, the electricity supply to the duct fan must be absolutely cut off.

 Access to the device by parties like unauthorised people, children and animals is forbidden and should be prevented or at least hindered.

 The device cannot work with covered or restricted air inlet or outlet (e. g. as a result of not keeping the minimum distances from partitions or obstructed inlet/outlet).

 The unit is designed for handling of air at temperature ranging from -30°C to 60°C and with relative humidity ≤ 90%.

 In case of any malfunctions (like blow a fuse, unusual noise etc.), immediately cut off the device from the electrical system and contact directly with the installer, the importer or the distributor. It is forbidden to turn on the unit before diagnosing and removing the reason of this malfunction.

 If the device is not used for a longer time, disconnect the unit from the electrical installation.

 Periodical inspection and maintenance of the device according to the guidelines below, should be carried out at least once a year and always after two-weeks or a longer period of inactivity.

 Before starting any maintenance work, the duct fan must be disconnected from the power supply.

 At the periodic inspection and maintenance, the following should be successively done:

- check the condition of the wiring for its damage and remove/repair any damage
- clean the fan and its housing from residue with a soft cloth
- connect the device to the power supply and assess if the fan works correctly at each stage; additional murmur, metallic reverberation, grinding noise, vibration etc. says about a malfunction - in such case, immediately cut off the device from the electrical system and contact directly with the installer, the importer or the distributor

 Inspection and maintenance of the duct fan should be carried out by a user who is familiar with this instruction or by an external entity if due to the way of assembly or local regulations additional authorisations like e. g. working with electricity or at heights are required.

 The frequency of the service should depend on the actual dirtiness - if the device is operating in an environment with a high concentration of dust, periodic cleaning should be performed much more often.

After exploitation time, please utilise the unit according to the local regulations.

6. CONTROLS

Using of control dedicated to FR series gives vast possibilities of adjusting the efficiency of the unit in different degree of automation, depending on the needs.

PROGRAMMABLE CONTROLLER HMI SINGLE

The controller is used to regulate devices equipped with 1-stage fans. It is an advanced controller with many functions i. a. operation in heating, cooling or mixed mode, programmable mode, valve control, automatic selection of the fan speed. Together with the controller the external sensor is provided, which allows to read the temperature in the required place, even remote from the controller. In addition, the device can operate in one of two modes - thermostatic or temperature difference. The second one enables effective controlling of destratification fans. The controller can be integrated with the BMS building control system (using the MODBUS communication protocol).

Voltage / Frequency: 230 V AC / 50 - 60 Hz
Maximum current load: 5 A
Operating temperature range: 0 - 45°C
Regulation range: 5°C - 35°C
Regulation accuracy: 0,5°C
External temperature sensor: NTC 10K
Communication (BMS): RS485
Dimensions: 86 x 86 x 13,3 mm
Weight: 0,27 kg
Degree of protection (housing): IP 20
Degree of protection (external sensor): IP 68

FAN SPEED CONTROLLER HC

The controller is designed to change the single-phase fan's speed by changing the supply voltage. The item has the 5-level knob which enables to change the supply voltage - level 1 represents the lowest voltage while level 5 represents the nominal voltage (i. e. 230 V). The levels 2-4 represents the intermediate vales of voltages. The selection of the appropriate model depends on the number of the devices that will be connected to the to one regulator - the total intensity of the connected devices cannot exceed the maximum current flow of the regulator.

Voltage / Frequency: 230 V AC / 50 - 60 Hz
Maximum current load (depending on model):
1,2 A, 3 A, 5 A, 7 A or 14 A
Protection: thermal switch
Weight (depending on model):
1,45 kg, 2,5 kg, 4,5 kg, 5,5 kg or 10,5 kg
Degree of protection (housing): IP 54



THYRISTOR SPEED CONTROLLER TRO

The controller enables reduction of rotational speed by lowering the supply voltage for a single phase motor by the phase cutting method. It is available in two variants - for motors with a power below 150 W, TRO 150W is recommended, for those with a power between 150 - 600 W, TRO 600W is recommended.



Voltage/Frequency: 220 ~ 240 V / 50 ~ 60 Hz

Maximum load:

150 W for TRO-150W

600 W for TRO-600W

Operating range: $t = -20 - 55^{\circ}\text{C}$, $20\% < \varphi < 90\%$

Housing material: ABS (fireproof)

Dimensions (TRO-150W): 86 x 86 x 42 mm

Dimensions (TRO-600W): 86 x 86 x 40 mm

7. WIRING DIAGRAMS

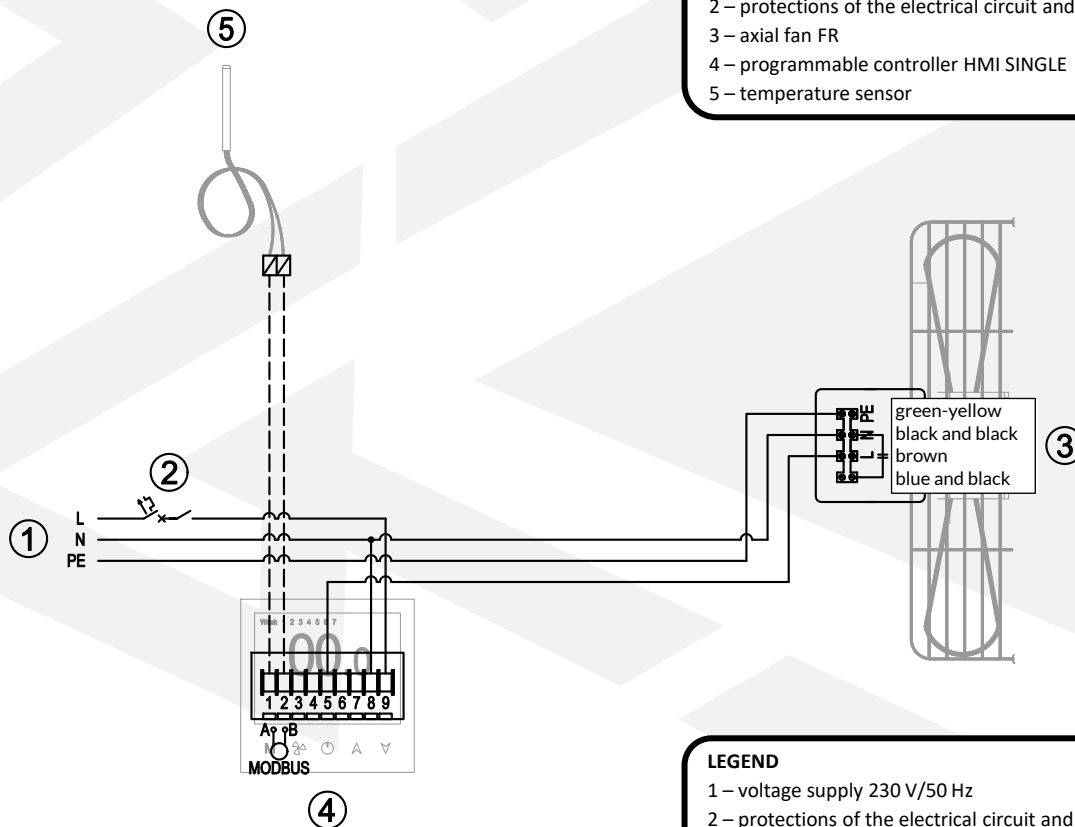

LEGEND

- 1 – voltage supply 230 V/50 Hz
- 2 – protections of the electrical circuit and ON/OFF switch
- 3 – axial fan FR
- 4 – programmable controller HMI SINGLE
- 5 – temperature sensor

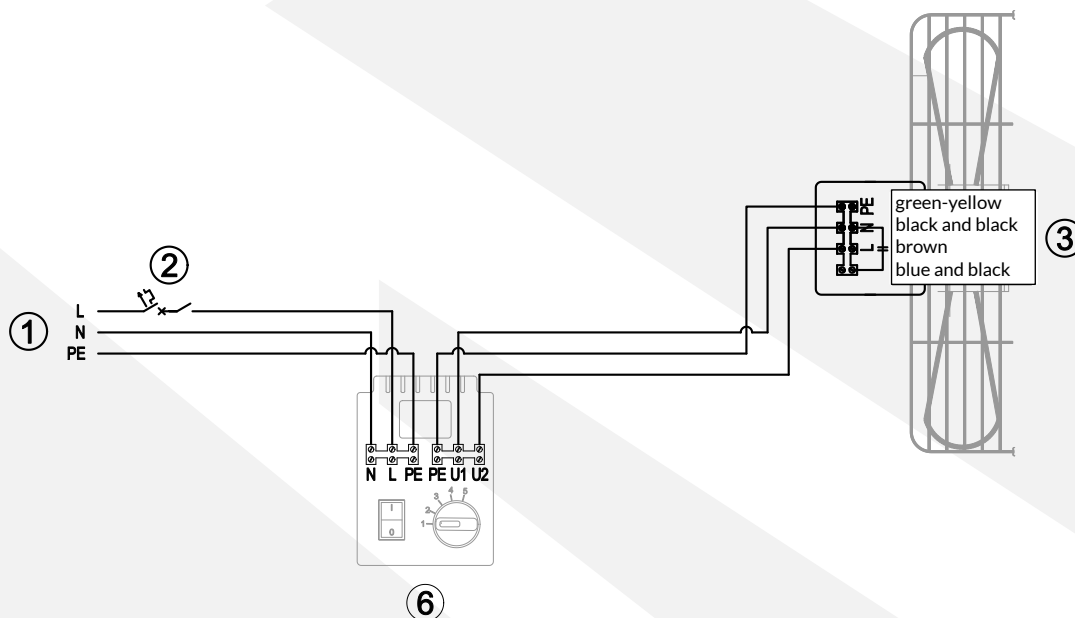

LEGEND

- 1 – voltage supply 230 V/50 Hz
- 2 – protections of the electrical circuit and ON/OFF switch
- 3 – axial fan FR
- 6 – fan speed controller HC

RELAY MODULE RM-16A

The relay enables to control of electricity devices (e. g. fans) which consume higher current that the permissible one for a connected regulator.



Voltage / Frequency: 230 V AC / 50 - 60 Hz

Maximum current load: 16 A

Inputs: dry contact NO/COM and SL voltage

Output: relay NO/COM/NC

Dimensions: 47 x 47 x 20 mm

LEGEND

- 1 – voltage supply 230 V/50 Hz
- 2 – protections of the electrical circuit and ON/OFF switch
- 3 – axial fan FR
- 7 - thyristor speed controller TRO

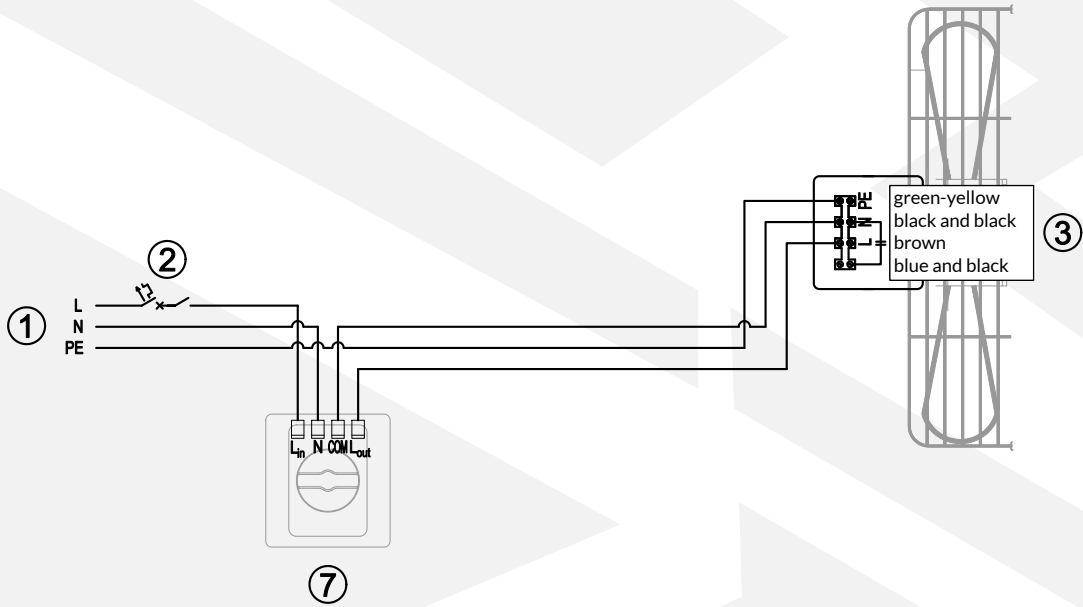

LEGEND

- 1 – voltage supply 230 V/50 Hz
- 2 – protections of the electrical circuit and ON/OFF switch
- 3 – axial fan FR
- 4 – programmable controller HMI SINGLE
- 5 – temperature sensor
- 8 – relay module RM-16A

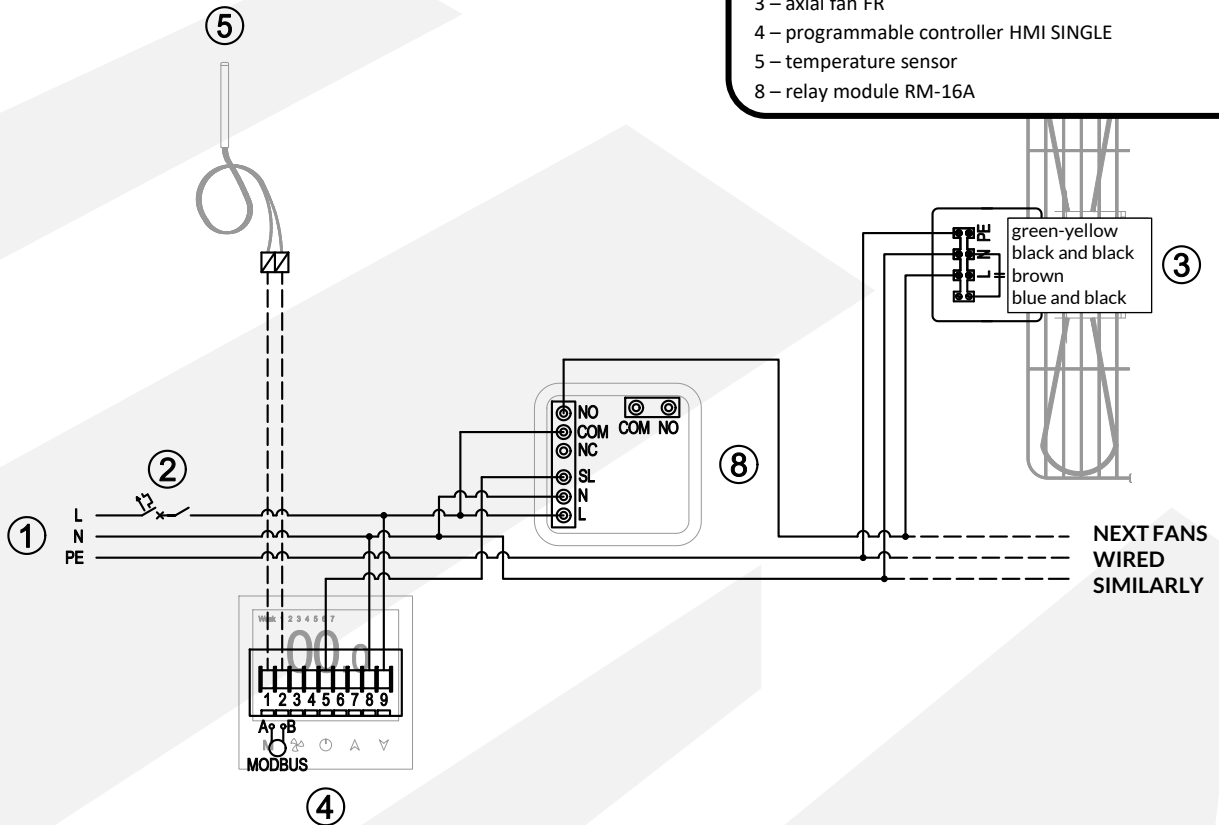

8. WARRANTY TERMS

I. The company Reventon Group Sp. z o. o. [Ltd.], hereinafter referred to as the guarantor, provides 24-month warranty protection period for the following devices:

- axial fan FR-200-BS and FR-200-BC
- axial fan FR-250-BG, FR-250-SG, FR-250-BS and FR-250-BC
- axial fan FR-300-BG, FR-300-SG, FR-300-BS and FR-300-BC
- axial fan FR-350-BG, FR-350-SG, FR-350-BS and FR-350-BC
- axial fan FR-400-BG, FR-400-SG, FR-400-BS and FR-400-BC
- axial fan FR-450-BG, FR-450-SG, FR-450-BS and FR-450-BC
- axial fan FR-500-BG, FR-500-SG, FR-500-BS and FR-500-BC
- axial fan FR-550-BG, FR-550-SG, FR-550-BS and FR-550-BC
- axial fan FR-630-BG, FR-630-SG, FR-630-BS and FR-630-BC
- axial fan FR-710-BG, FR-710-SG and FR-710-BS
- axial fan FR-800-BG, FR-800-SG and FR-800-BS

II. The warranty protection is valid from the purchasing date by end user (i.e. the issue date of invoice) but not longer than 30 months from leaving the warehouse of Reventon Group Sp. z o. o. [Ltd.].

III. The warranty claim should be reported via the complaint form on the website (<https://reventongroup.eu/en/complaints>). The scan or the photo of the fulfilled Warranty Card and the purchase invoice must be attached to the form. The Warranty Card is not required in case of accessories.

IV. The guarantor is committed to consider the claim within 14 working days since the date of reporting (i. e. the day of receipt of the correctly fulfilled warranty form).

V. In exceptional cases, the guarantor reserves the right to extend the time for consideration of the request, especially if the defect is not permanent one and its determination requires a deeper analysis. The extension must be notified by the guarantor before the end of the 14th working day.

VI. Under the warranty, the guarantor provides a repairment, replacement (the device or its component) or refund for the defective item within a specified time.

VII. In the case of replacement of a device component, the warranty protection of the whole unit is not prolonged.

VIII. The guarantor does not cover the costs of disassembly and eventual reassembly of the complaint device.

IX. The guarantor may decide to bring the defective device or its component to the service of Reventon Group Sp. z o. o. [Ltd.]. In such case the transport of the item is organised and paid by the guarantor. The responsibility of the device's owner is to prepare the item for the shipment - the device must be packed in a way which protects it against transport damages and the dimensions and weight of the package must not exceed 660 x 650 x 400 mm and 30 kg respectively. In the case of elements which cannot be packed in this way, the method of shipment must be agreed and approved by Reventon Group Sp. z o. o. [Ltd.]. In the case of sending a non-standard package without agreement of the service of Reventon Group Sp. z o. o. [Ltd.], the guarantor reserves the right to charge the owner of device with all additional transport costs.

X. In the case of arrival of the authorized service of the guarantor or an installer to fix the complaint item, the customer must ensure them seamless access to the device and all required media like electricity, water, lighting etc. free of charge.

XI. The warranty protection does not cover the parts of the device subject to the normal usage and the following cases:

a) mechanical damage of the product

b) defects and damages through:

- improper storage or transport

- improper or non-compliant use and maintenance (i. e. inconsistent with the manual)

- using the device in the improper conditions (too high humidity, too high or too low temperature, impact of the surrounding, sun etc.)

- unauthorized (i. e. by the user or other unauthorized persons) repairs, modifications or construction changes

- connecting equipment inconsistent with the technical documentation

- connecting additional equipment, which is not recommended by the guarantor

- improper power supply

- random events (like fire, flood, storm etc.)

c) elements which wear and tear such as discolour of the housing

If there is any of the above, the claimant will be charged for transport and / or repairs.

XII. During collection of the device, the item must be checked exactly by the receiver to exclude transport damages. If any of them is observed, the damage report in presence of the product deliverer have to be filled - such report is the basement for the warranty claim. The damage report must be provided by the product deliverer.

XIII. The guarantor does not take the responsibility for potential losses and damages related to the downtime of the device during its failure and the complaint considering time.

XIV. Any changes in the Warranty Terms, improper use of the product as well as traces of self repairing (beyond the guarantor service) or alterations cause, the warranty become invalid.

XV. These Warranty Terms do not exclude or limit any rights arising from the pledge.

XVI. Not following to any of the warranty regulations makes the protection invalid.

XVII. All correspondence should be sent to the following address: Reventon Group Sp. z o.o. [Ltd.], 556 Wyzwolenia Street, 43 340 Kozy, Poland or email address: serwis@reventongroup.eu.

Warranty Card

1 - Model and serial number* or product code	2 - Address and place of assembly
3 - Date of connection to:	4 - Stamp and signature of installer:
Heating/cooling installation (if applicable)	
Ventilation installation (if applicable)	
Electrical installation (if applicable)	

* serial number is required only for water heaters HC-3S, HC-EC and FARMER HCF series and recovery units INSPIRO, INSPIRO BASIC and VERTIC series

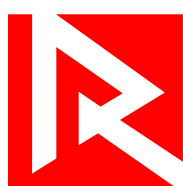

reventon
INDUSTRIAL SOLUTIONS

Reventon Group Sp. z o.o. [Ltd.], 556 Wyzwolenia Street, 43-340 Kozy, Poland, www.reventongroup.eu