



Installation and Operation Instructions  
**THERMAL STORES with stainless-steel DHW tube heat exchanger**  
**HSK 600 PV, HSK 750 PV, HSK1000 PV, HSK 1700 PV**

## CONTENTS

<b>1 Description</b> .....	<b>3</b>
1.1 Models .....	3
1.2 Tank protection .....	3
1.3 Thermal insulation .....	3
1.4 Packaging .....	3
<b>2 General Information</b> .....	<b>3</b>
<b>3 Technical Data and Dimensions of HSK PV Model Line</b> .....	<b>4</b>
<b>4 Operation</b> .....	<b>12</b>
<b>5 Typical Layout Examples with Thermal Store</b> .....	<b>12</b>
<b>6 Installation and Commissioning</b> .....	<b>13</b>
<b>7 Installing Insulation on the Tank</b> .....	<b>13</b>
<b>8 Maintenance</b> .....	<b>15</b>
<b>9 Disposal</b> .....	<b>15</b>
<b>10 Warranty</b> .....	<b>15</b>

## 1 - Description

HSK PV Thermal Stores are intended for storing and subsequent distribution of thermal energy of heating water. They are fitted with a stainless-steel tube DHW heat exchanger, permitting installation of electric heating elements and connection of other heat sources. For a better thermal layering, the tank volume is separated by a baffle.

For proper operation of a tank, it is necessary to have an optimum hydraulic design of the entire heating system, i.e. position of circulation pumps for both heat sources and heating circuits, valves, check valves etc. When more heat sources shall be combined, it is recommended to use a smart controller for both the heat source and heat sink sides of a heating circuit, i.e. also for charging and discharging a thermal store.

### 1.1 - Models

Four models of 557, 757, 922 and 1684 l total volume, with stainless-steel tube DHW heat exchanger.

### 1.2 - Tank protection

The thermal store has no inner surface finish, the outer surface is painted in gray. The DHW heat exchanger is made of stainless steel.

### 1.3 - Thermal insulation

Thermal insulation is available as a separate item. For easier handling, the insulation shall not be fitted on the tank until it reaches its definite place of installation. This is a fleece insulation, 100 mm thick, with a hard polystyrene surface. It is closed by quick locks.

### 1.4 - Packaging

Thermal stores are delivered standing, each screwed to its pallet, packed in bubble wrap.

**It is forbidden to transport and/or store the thermal stores in a horizontal position.**

## 2 - General Information

This Owners Manual is an integral and important part of the product and must be handed over to the User. Read carefully the instructions in this Manual as they contain important information concerning safety, installation, operation and maintenance. Keep this Manual for later reference. The appliance shall be installed by a qualified person according to valid rules and Manufacturer's Instructions.

This appliance is designed to accumulate thermal energy and distribute it subsequently. It must be connected to a heating system and heat sources. This appliance is suitable for continuous heating of domestic hot water.

Using the thermal store for other purposes than above described is forbidden and the manufacturer accepts no responsibility for damage caused by improper or wrong use or filling procedure.

The appliance shall be installed by a qualified person according to valid rules, otherwise the warranty becomes null and void.

### 3 - Technical Data and Dimensions of HSK PV Model Line

#### HSK 600 PV Combination Thermal Store

HSK 600 PV



HSK 600 PV with insulation

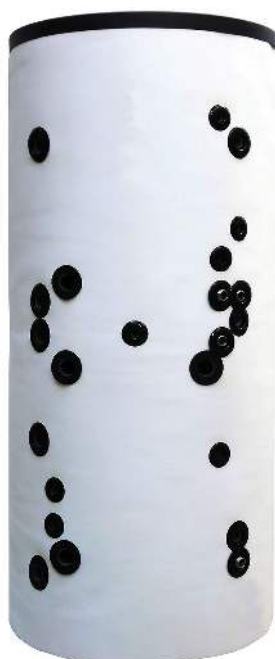

Main features	
Application	accumulation of thermal energy for space and DHW heating
Description	this combination Thermal Store utilizes a heat pump with PV panels as a heat source for both space and DHW heating; DHW is being prepared in 2 integrated stainless-steel heat exchangers; a tightly fitting separating metal plate increases the heat pump's seasonal coefficient of performance, a dedicated PV heating element is placed in the lower tank section; more electric heating elements can be installed if needed
Working fluid	water (DHW heat exchanger) water; water/glycol mixture (max. 1:1) or water/glycerine mixture (max. 2:1) (thermal store)

Code	
Thermal Store	<b>16158</b>
Insulation	<b>18839</b>

Energy Efficiency Data (as per EC Regulation No. 812/2013)	
	<b>HSK 600 PV with insulation</b>
Energy efficiency class	N/A
Standing loss	99 W
Storage volume	557 l

Technical Data	
Total tank volume	557 l
Fluid volume in tank	525 l
Fluid volume above the separating plate	235 l
Fluid volume below the separating plate	290 l
Upper DHW heat exchanger volume	21 l
Lower DHW heat exchanger volume	11 l
DHW heat exchanger surface area	6 m <sup>2</sup>
Plocha výměníku TV pod dělicím plechem	3 m <sup>2</sup>
Max. working temperature in Thermal Store	95 °C
Max. working temperature in DHW HE	95 °C
Max. working pressure in Thermal Store	4 bar
Max. working pressure in DHW HE	10 bar

Tank Materials	
Tank material	S235JR
DHW heat exchanger material	AISI 316 L

Insulation Materials	
Tank perimeter insulation	fleece
Tank perimeter insulation outer surface	hard polystyrene
Top and bottom tank insulation	fleece

Dimensions, Tipping height, Insulation thickness, Weight	
Tank diameter	650 mm
Tank diameter with insulation	850 mm
Tank overall height	1935 mm
Tipping height without insulation	2050 mm
Tank perimeter insulation thickness	100 mm
Bottom insulation thickness	50 mm
Top insulation thickness	120 mm
Empty weight without insulation	157 kg

## HSK 600 PV Combination Thermal Store

### Dimensions

Tipping height without insulation 2050 mm

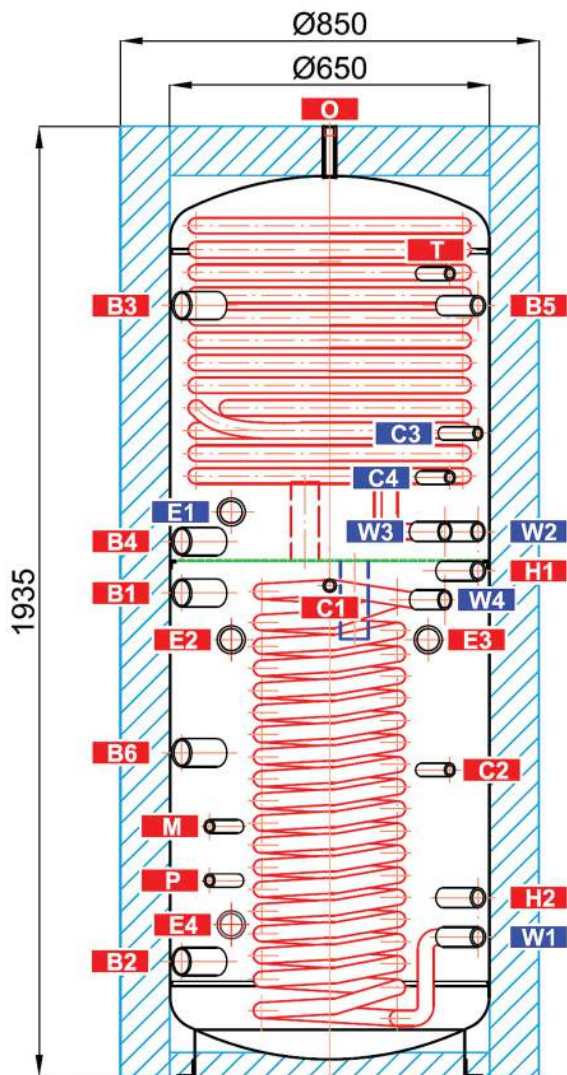

### TAPPINGS

pos.	description	connec- tion	height [mm]
<b>Heat sources</b>			
B1	Incoming from heat source	G 6/4" F	985
B2	Return to heat source	G 6/4" F	135
B3	Incoming from heat source	G 6/4" F	1570
B4	Return to heat source	G 6/4" F	1090
B5	Incoming from heat source	G 1" F	1570
B6	Incoming from heat source	G 6/4" F	660
<b>Heating system</b>			
H1	Supply to the heating circuit	G 1" F	1030
H2	Returnable from the heating circuit	G 1" F	365
<b>El. heating elements</b>			
E1	Electric heating element for DHW heating	G 6/4" F	1150
E2	Electric heating element for space heating	G 6/4" F	890
E3	Electric heating element for space heating	G 6/4" F	890
E4	Electric heating element for PV system	G 6/4" F	310
<b>DHW heating</b>			
W1	Cold water	G 1" M	285
W2	Hot water	G 1" M	1110
W3	Circulation	G 1" M	1110
W4	Hot water	G 1" M	970
<b>Control and safety</b>			
C1	Temperature sensor	G 1/2" F	1000
C2	Temperature sensor	G 1/2" F	625
C3	Temperature sensor	G 1/2" F	1310
C4	Temperature sensor	G 1/2" F	1220
T	Thermometer	G 1/2" F	1635
M	Pressure gauge	G 1/2" F	510
P	Safety valve	G 1/2" F	400
<b>Air release</b>			
O	Air vent valve	G 1/2" F	1935

## HSK 750 PV Combination Thermal Store

HSK 750 PV



HSK 750 PV with insulation



Main features	
Application	accumulation of thermal energy for space and DHW heating
Description	this combination Thermal Store utilizes a heat pump with PV panels as a heat source for both space and DHW heating; DHW is being prepared in 2 integrated stainless-steel heat exchangers; a tightly fitting separating metal plate increases the heat pump's seasonal coefficient of performance, a dedicated PV heating element is placed in the lower tank section; more electric heating elements can be installed if needed
Working fluid	water (DHW heat exchanger) water; water/glycol mixture (max. 1:1) or water/glycerine mixture (max. 2:1) (thermal store)

Code	
Thermal Store	<b>16177</b>
Insulation	<b>18842</b>

Energy Efficiency Data (as per EC Regulation No. 812/2013)	
<b>HSK 750 PV with insulation</b>	
Energy efficiency class	N/A
Standing loss	117 W
Storage volume	757 l

Technical Data	
Total tank volume	757 l
Fluid volume in tank	725 l
Fluid volume above the separating plate	304 l
Fluid volume below the separating plate	421 l
Upper DHW heat exchanger volume	21 l
Lower DHW heat exchanger volume	11 l
DHW heat exchanger surface area	6 m <sup>2</sup>
Plocha výměníku TV pod dělicím plechem	3 m <sup>2</sup>
Max. working temperature in Thermal Store	95 °C
Max. working temperature in DHW HE	95 °C
Max. working pressure in Thermal Store	4 bar
Max. working pressure in DHW HE	10 bar

Tank Materials	
Tank material	S235JR
DHW heat exchanger material	AISI 316 L

Insulation Materials	
Tank perimeter insulation	fleece
Tank perimeter insulation outer surface	hard polystyrene
Top and bottom tank insulation	fleece

Dimensions, Tipping height, Insulation thickness, Weight	
Tank diameter	750 mm
Tank diameter with insulation	950 mm
Tank overall height	1975 mm
Tipping height without insulation	2120 mm
Tank perimeter insulation thickness	100 mm
Bottom insulation thickness	50 mm
Top insulation thickness	120 mm
Empty weight without insulation	170 kg

## HSK 750 PV Combination Thermal Store

### Dimensions

Tipping height without insulation 2120 mm

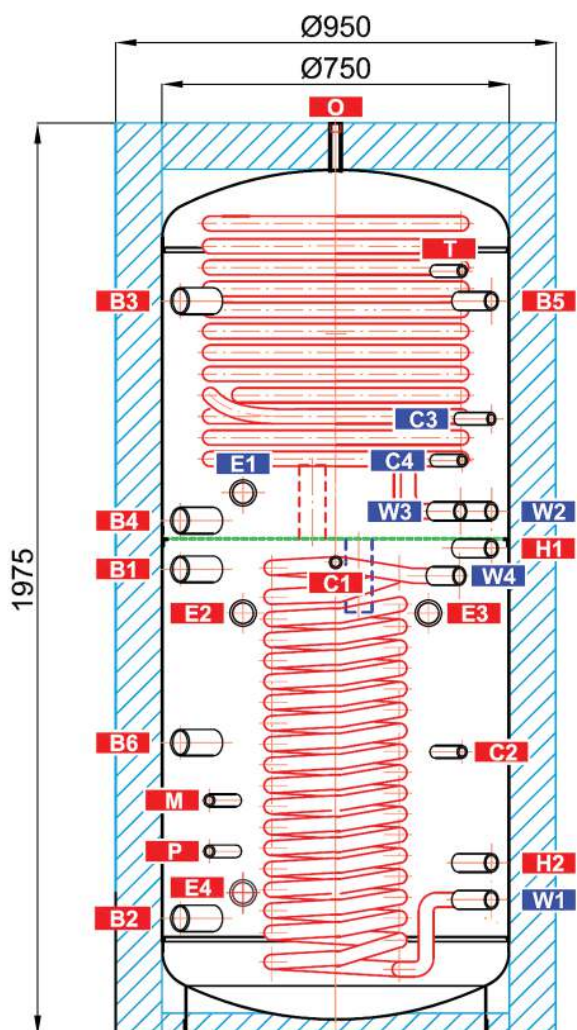

### TAPPINGS

pos.	description	connec- tion	height [mm]
<b>Heat sources</b>			
B1	Incoming from heat source	G 6/4" F	1010
B2	Return to heat source	G 6/4" F	155
B3	Incoming from heat source	G 6/4" F	1590
B4	Return to heat source	G 6/4" F	1115
B5	Incoming from heat source	G 1" F	1590
B6	Incoming from heat source	G 6/4" F	635
<b>Heating system</b>			
H1	Supply to the heating circuit	G 1" F	1055
H2	Returnable from the heating circuit	G 1" F	375
<b>EI . heating elements</b>			
E1	Electric heating element for DHW heating	G 6/4" F	1175
E2	Electric heating element for space heating	G 6/4" F	915
E3	Electric heating element for space heating	G 6/4" F	915
E4	Electric heating element for PV system	G 6/4" F	310
<b>DHW heating</b>			
W1	Cold water	G 1" M	295
W2	Hot water	G 1" M	1135
W3	Circulation	G 1" M	1135
W4	Hot water	G 1" M	995
<b>Control and safety</b>			
C1	Temperature sensor	G 1/2" F	1025
C2	Temperature sensor	G 1/2" F	615
C3	Temperature sensor	G 1/2" F	1335
C4	Temperature sensor	G 1/2" F	1245
T	Thermometer	G 1/2" F	1655
M	Pressure gauge	G 1/2" F	510
P	Safety valve	G 1/2" F	400
<b>Air release</b>			
O	Air vent valve	G 1/2" F	1975

## HSK 1000 PV Combination Thermal Store

HSK 1000 PV



HSK 1000 PV with insulation



Main features	
Application	accumulation of thermal energy for space and DHW heating
Description	this combination Thermal Store utilizes a heat pump with PV panels as a heat source for both space and DHW heating; DHW is being prepared in 2 integrated stainless-steel heat exchangers; a tightly fitting separating metal plate increases the heat pump's seasonal coefficient of performance, a dedicated PV heating element is placed in the lower tank section; more electric heating elements can be installed if needed
Working fluid	water (DHW heat exchanger) water; water/glycol mixture (max. 1:1) or water/glycerine mixture (max. 2:1) (thermal store)

Code	
Thermal Store	<b>16180</b>
Insulation	<b>18845</b>

Energy Efficiency Data (as per EC Regulation No. 812/2013)	
	<b>HSK 1000 PV with insulation</b>
Energy efficiency class	N/A
Standing loss	129 W
Storage volume	922 l

Technical Data	
Total tank volume	922 l
Fluid volume in tank	890 l
Fluid volume above the separating plate	314 l
Fluid volume below the separating plate	576 l
Upper DHW heat exchanger volume	21 l
Lower DHW heat exchanger volume	11 l
DHW heat exchanger surface area	6 m <sup>2</sup>
Plocha výměníku TV pod dělicím plechem	3 m <sup>2</sup>
Max. working temperature in Thermal Store	95 °C
Max. working temperature in DHW HE	95 °C
Max. working pressure in Thermal Store	4 bar
Max. working pressure in DHW HE	10 bar

Tank Materials	
Tank material	S235JR
DHW heat exchanger material	AISI 316 L

Insulation Materials	
Tank perimeter insulation	fleece
Tank perimeter insulation outer surface	hard polystyrene
Top and bottom tank insulation	fleece

Dimensions, Tipping height, Insulation thickness, Weight	
Tank diameter	800 mm
Tank diameter with insulation	1000 mm
Tank overall height	2080 mm
Tipping height without insulation	2230 mm
Tank perimeter insulation thickness	100 mm
Bottom insulation thickness	50 mm
Top insulation thickness	120 mm
Empty weight without insulation	192 kg



## HSK 1000 PV Combination Thermal Store

### Dimensions

Tipping height without insulation 2230 mm

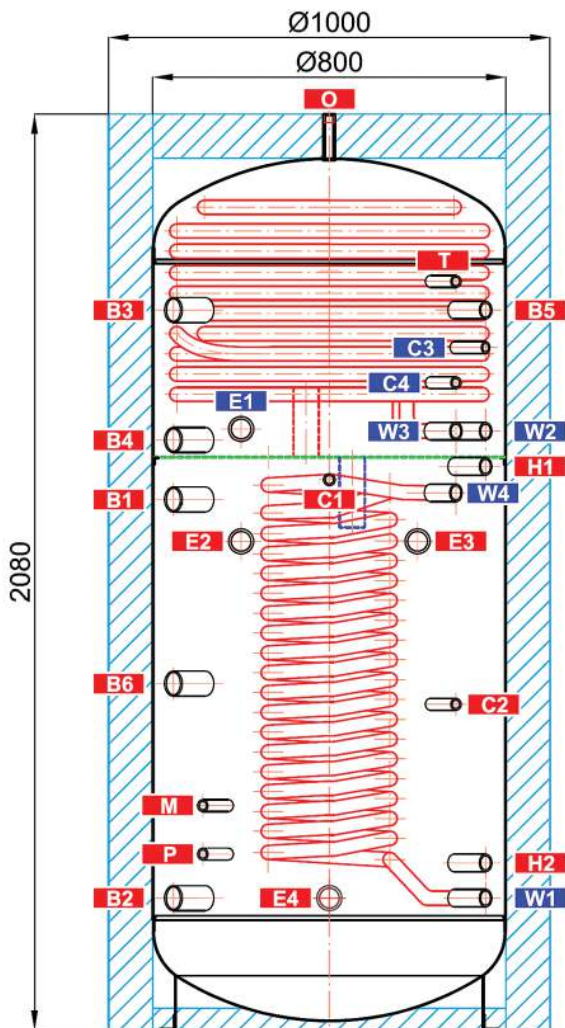

### TAPPINGS

pos.	description	connec- tion	height [mm]
<b>Heat sources</b>			
B1	Incoming from heat source	G 6/4" F	1205
B2	Return to heat source	G 6/4" F	200
B3	Incoming from heat source	G 6/4" F	1635
B4	Return to heat source	G 6/4" F	1340
B5	Incoming from heat source	G 1" F	1635
B6	Incoming from heat source	G 6/4" F	787
<b>Heating system</b>			
H1	Supply to the heating circuit	G 1" F	1280
H2	Returnable from the heating circuit	G 1" F	380
<b>EI . heating elements</b>			
E1	Electric heating element for DHW heating	G 6/4" F	1365
E2	Electric heating element for space heating	G 6/4" F	1110
E3	Electric heating element for space heating	G 6/4" F	1110
E4	Electric heating element for PV system	G 6/4" F	300
<b>DHW heating</b>			
W1	Cold water	G 1" M	300
W2	Hot water	G 1" M	1360
W3	Circulation	G 1" M	1360
W4	Hot water	G 1" M	1220
<b>Control and safety</b>			
C1	Temperature sensor	G 1/2" F	1250
C2	Temperature sensor	G 1/2" F	740
C3	Temperature sensor	G 1/2" F	1550
C4	Temperature sensor	G 1/2" F	1470
T	Thermometer	G 1/2" F	1700
M	Pressure gauge	G 1/2" F	510
P	Safety valve	G 1/2" F	400
<b>Air release</b>			
O	Air vent valve	G 1/2" F	2080

## HSK 1700 PV Combination Thermal Store

HSK 1700 PV



HSK 1700 PV s izolací

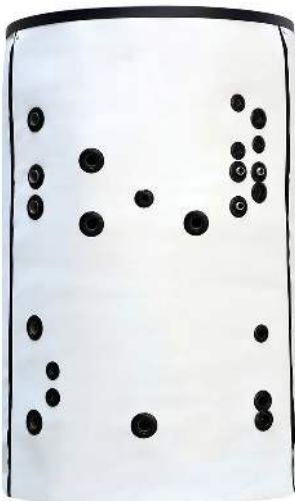

Main features	
Application	accumulation of thermal energy for space and DHW heating
Description	this combination Thermal Store utilizes a heat pump with PV panels as a heat source for both space and DHW heating; DHW is being prepared in 2 integrated stainless-steel heat exchangers; a tightly fitting separating metal plate increases the heat pump's seasonal coefficient of performance, a dedicated PV heating element is placed in the lower tank section; more electric heating elements can be installed if needed
Working fluid	water (DHW heat exchanger) water; water/glycol mixture (max. 1:1) or water/glycerine mixture (max. 2:1) (thermal store)

Code	
Thermal Store	<b>16183</b>
Insulation	<b>18848</b>

Energy Efficiency Data (as per EC Regulation No. 812/2013)	
<b>HSK 1700 PV with insulation</b>	
Energy efficiency class	N/A
Standing loss	175 W
Storage volume	1684 l

Technical Data	
Total tank volume	1684 l
Fluid volume in tank	1652 l
Fluid volume above the separating plate	550 l
Fluid volume below the separating plate	1102 l
Upper DHW heat exchanger volume	21 l
Lower DHW heat exchanger volume	11 l
DHW heat exchanger surface area	6 m <sup>2</sup>
Plocha výměníku TV pod dělicím plechem	3 m <sup>2</sup>
Max. working temperature in Thermal Store	95 °C
Max. working temperature in DHW HE	95 °C
Max. working pressure in Thermal Store	3 bar
Max. working pressure in DHW HE	10 bar

Tank Materials	
Tank material	S235JR
DHW heat exchanger material	AISI 316 L

Insulation Materials	
Tank perimeter insulation	fleece
Tank perimeter insulation outer surface	hard polystyrene
Top and bottom tank insulation	fleece

Dimensions, Tipping height, Insulation thickness, Weight	
Tank diameter	1100 mm
Tank diameter with insulation	1300 mm
Tank overall height	2075 mm
Tipping height without insulation	2350 mm
Tank perimeter insulation thickness	100 mm
Bottom insulation thickness	50 mm
Top insulation thickness	120 mm
Empty weight without insulation	295 kg

## HSK 1700 PV Combination Thermal Store

### Dimensions

Tipping height without insulation 2350 mm

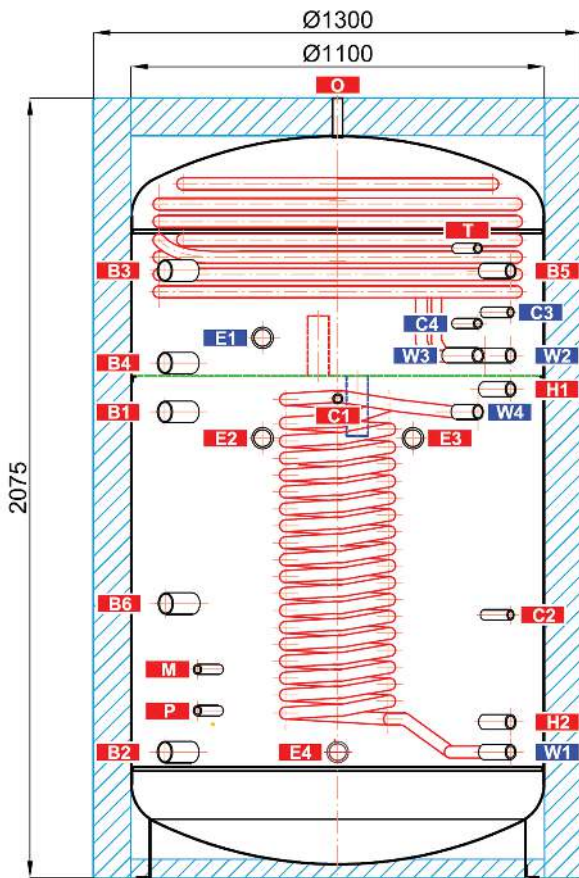

### TAPPINGS

pos.	description	connec- tion	height [mm]
<b>Heat sources</b>			
B1	Incoming from heat source	G 6/4" F	1240
B2	Return to heat source	G 6/4" F	235
B3	Incoming from heat source	G 6/4" F	1615
B4	Return to heat source	G 6/4" F	1370
B5	Incoming from heat source	G 1" F	1615
B6	Incoming from heat source	G 6/4" F	730
<b>Heating system</b>			
H1	Supply to the heating circuit	G 1" F	1300
H2	Returnable from the heating circuit	G 1" F	415
<b>E1 . heating elements</b>			
E1	Electric heating element for DHW heating	G 6/4" F	1437
E2	Electric heating element for space heating	G 6/4" F	1170
E3	Electric heating element for space heating	G 6/4" F	1170
E4	Electric heating element for PV system	G 6/4" F	335
<b>DHW heating</b>			
W1	Cold water	G 1" M	335
W2	Hot water	G 1" M	1390
W3	Circulation	G 1" M	1390
W4	Hot water	G 1" M	1240
<b>Control and safety</b>			
C1	Temperature sensor	G 1/2" F	1275
C2	Temperature sensor	G 1/2" F	700
C3	Temperature sensor	G 1/2" F	1505
C4	Temperature sensor	G 1/2" F	1475
T	Thermometer	G 1/2" F	1675
M	Pressure gauge	G 1/2" F	555
P	Safety valve	G 1/2" F	445
<b>Air release</b>			
O	Air vent valve	G 1/2" F	2075

## 4 - Operation

This tank is designed for heating and storing heating water in household or industrial applications, however always in closed pressure circuits with forced circulation. Hot water is heated inside the thermal store from several possible heat sources like various kinds of heating boilers, renewable energy sources or also electric heating elements. A stainless-steel tube DHW heat exchanger is heated by heating water inside the thermal store. It connects through 1" threaded fittings. When hot water is drawn from the outlet point, cold water flows into the immersed heat exchanger and heats up by the heating water.

The thermal store shall be connected to heat sources through connecting threaded fittings.

Individual connection points are assigned according to the circuits to be connected. There is a wide choice of combinations; the following chapter describes just some examples.

## 5 - Typical Layout Examples with Thermal Store

### Example I.

Heat pump + PV panels + el. heating elements

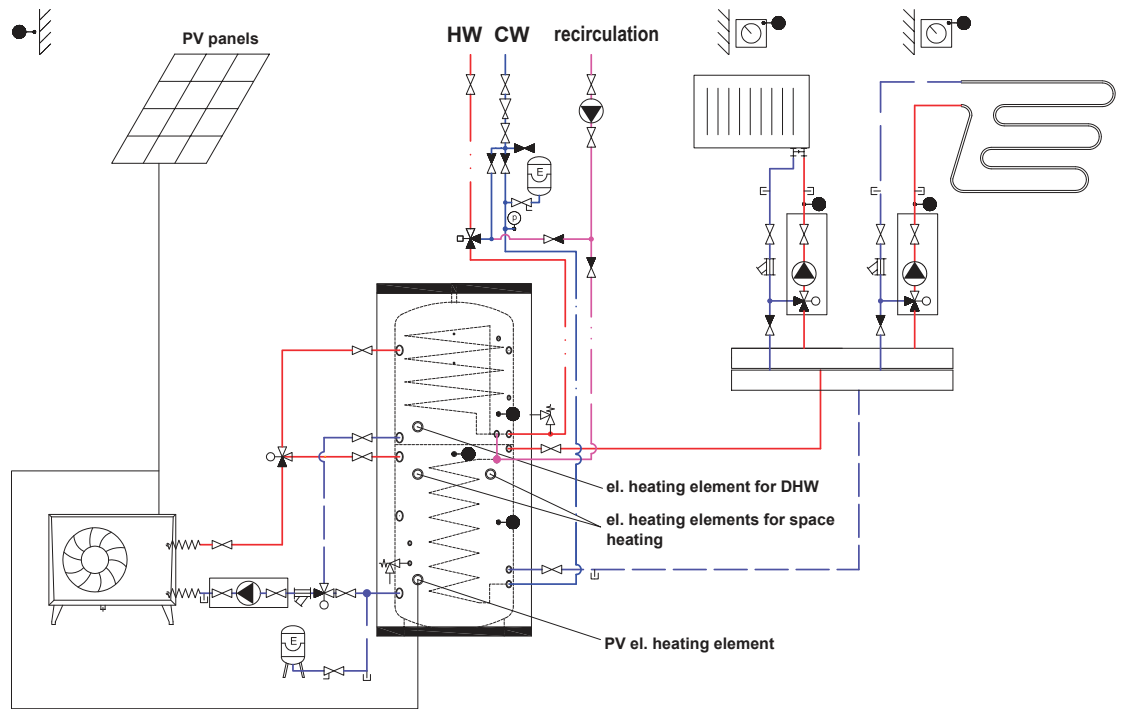

### Example II.

Heat pump + PV panels + gas boiler

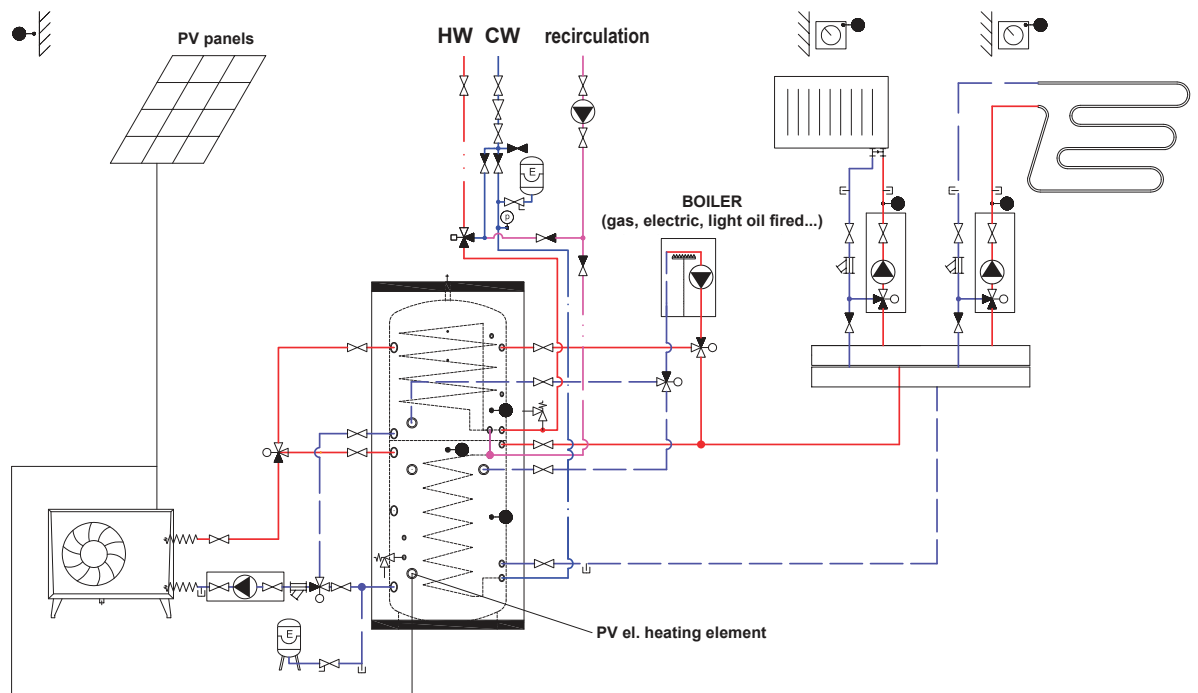

## 6 - Installation and Commissioning

Installation must meet valid rules and may be done only by qualified staff.

**Defects caused by improper installation, use or handling are not covered by warranty.**

After the tank is installed and connected to an existing heating system, it is recommended to clean the entire heating system using a suitable cleaning agent, e.g. MR-501/R.

Anti-corrosion protective liquid should be also used, e.g. MR-501/F.

### 6.1 - Connection to heat sources

Place the tank on the floor, as close to your heat source as possible. Connect the heating circuits to inlets and outlets respecting the thermal stratification in the tank. Install a drain valve at the lowest point of the tank. Install an air vent valve at the highest point of the system. Insulate all the connection piping

### 6.2 - Installation of an el. heating element

The G 6/4" side tapplings are designed to accommodate electric heating rods. They can be connected either directly to the mains (thermostat-equipped rods), or to a heating system controller. The installation may be done by qualified staff only.

**Warning: Electric heating elements shall be protected by a safety thermostat.**

### 6.3 - Connection to water mains

DHW piping shall be done according to valid rules. Installation of a pressure reducing valve on the immersed tank inlet is recommended. For water mains pressure above 6 bar a pressure reducing valve is necessary. To prevent water loss, we recommend installing an expansion vessel at the cold water inlet with a minimum volume of 4% of the total volume of water in the DHW piping, including heat exchangers, circulation pipes, etc. (usually 8 l). Should the water be too hard, install a water softener before the tank. In case the water contains mechanical impurities, install a strainer.

### Table of limit values for total dissolved solids in hot water.

Description	pH	Total dissolved solids (TDS)	Ca	Chlorides	Mg	Na	Fe
Max. value	6,5 - 9,5	600 mg/l	40 mg/l	100 mg/l	20 mg/l	200 mg/l	0,2 mg/l

### 6.4 - Commissioning

Ground the tank before commissioning.

The tank shall be filled up together with the heating system, respecting valid standards and rules. In order to minimize corrosion, special additives for heating systems should be used. The quality of heating water depends on the quality of filling water at commissioning, on the top-up water and on the frequency of topping up. This has a strong influence on the lifetime of heating systems. Poor quality of heating water may cause problems like corrosion or incrustation, esp. on heat transfer surfaces.

**Quality of DHW shall meet the conditions shown in the Table of limit values for total dissolved solids in hot water on this page.**

Fill the heating circuits with the appropriate fluids and air-bleed the entire system. Check all connections for leaks and verify the system pressure. Set the heating controller in compliance with the documentation and manufacturer's recommendations. Check regularly the proper function of all control and adjustment elements.

## 7 - Installing Insulation on the Tank

### Product description

Thermal insulation is a part of thermal stores, preventing heat loss. For easier handling, the insulation shall not be fitted on this type of thermal store until it reaches its definite place of installation.

### Warning

Insulation installation shall be done in two or three persons, depending on its size. The zippered, PVC coated fleece insulation **must not be installed at temperatures below 20 °C**. If this cannot be avoided, the insulation shall be pre-warmed in another room to at least 20 °C. It is impossible to install insulation of lower temperature, there is a risk of damage, esp. to the zipper.

Do not use any tools for installation.

Keep away from open fire.

### Installing Fleece Insulation

1. Fix the tank following installation instructions.

2. Wrap the insulation around the tank carefully. Check that the insulation adheres to its body perfectly. This can be reached by rubbing and patting the insulation by hand from its center evenly in both directions until the insulation adheres to the tank's surface completely and no bubbles are left.
3. Use the holes for tappings as a rest during the insulation installation.
4. At least one person presses the insulation to the tank, pulling both ends together. The other person closes the insulation lock from the side.
5. Put on the upper insulation and cover
6. Push on the covering plastic rosettes depending on the size of tappings, or put on the flange plug(s) with insulation.
7. Finish the tank installation in compliance with the respective instructions and valid standards and rules.

### Warranty on insulation

- Warranty shall become null and void if:
  - the procedure described in the Installation Manual was not respected,
  - the product was used for other purposes than intended.
- Warranty does not cover:
  - usual wear and tear,
  - damage caused by fire, water, electricity or a natural disaster,
  - defects caused by failure to use the product in compliance with its intended purpose, by improper use and insufficient maintenance,
  - defects caused by mechanical damage to the product,
  - defects caused by tampering or incompetent repair.

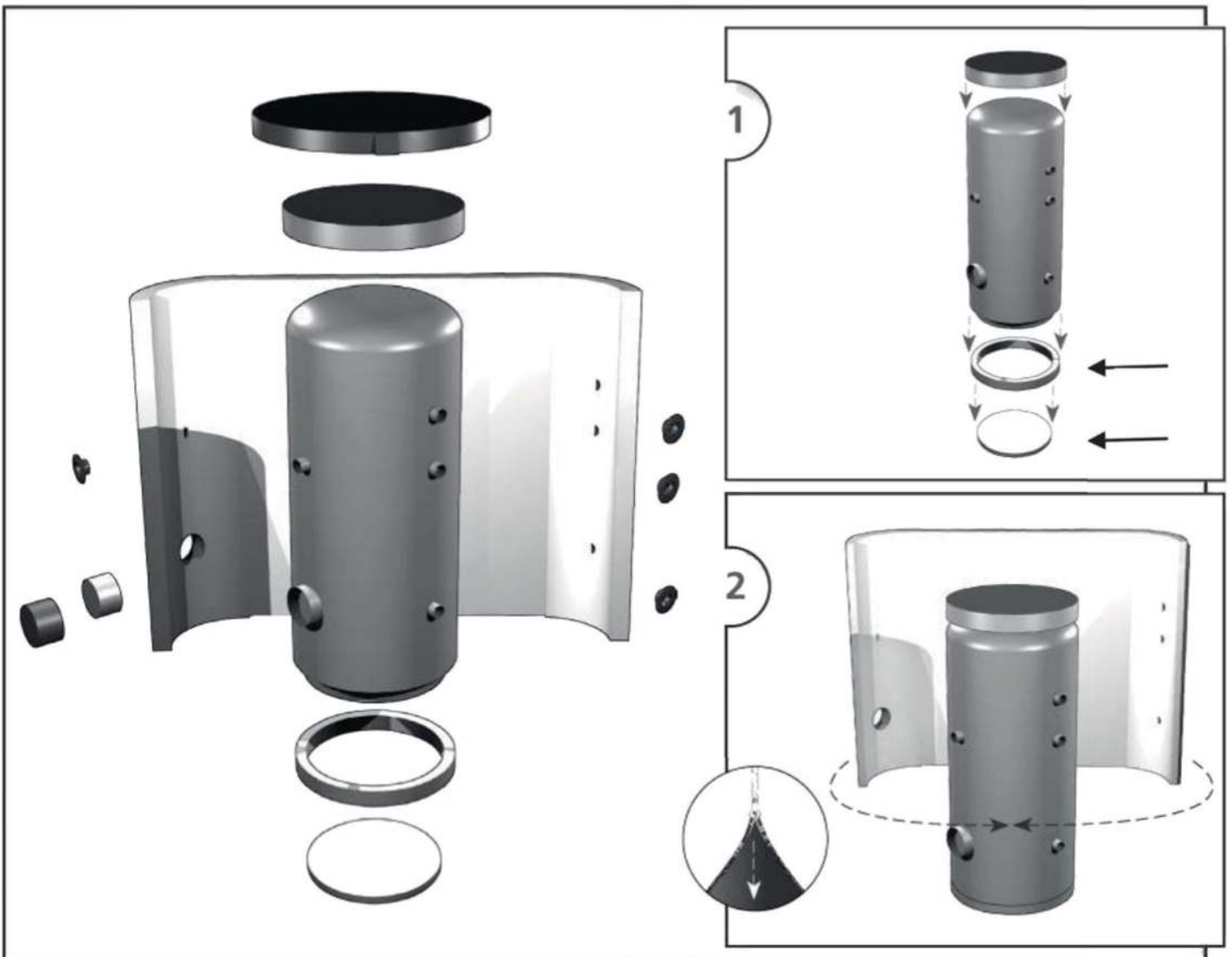

## **8 - Maintenance**

If the tank is fitted with a heating element, disconnect it from the mains first. Clean the exterior of the tank with a soft cloth and a mild detergent. Never use abrasive cleaners or solvents. Check all connections for leaks.

## **9 - Disposal**

Packaging shall be disposed of in compliance with the valid rules. When the product reaches the end of its life, it shall not be disposed of as household waste. It shall be dropped off at a Local Waste Recycling Center. Insulation shall be recycled as plastic and the steel vessel as scrap iron.

## **10 - Warranty**

This product is covered by warranty under conditions specified in this Manual and the respective Warranty Certificate. The Warranty Certificate is an integral part of supply of this Thermal Store.

