



DUO N P

Installation and Operation Manual  
**THERMAL STORES with immersed DHW tank**  
DUO 390/130 N P, DUO 600/200 N P, DUO 750/200 N P,  
DUO 1000/200 N P, DUO 1700/200 N P

EN

# CONTENTS

<b>1 Description</b> .....	<b>3</b>
1.1 Models .....	3
1.2 Tank protection .....	3
1.3 Thermal insulation .....	3
1.4 Packaging .....	3
<b>2 General Information</b> .....	<b>3</b>
<b>3 Technical Data and Dimensions of Regulus DUO N P series</b> .....	<b>4</b>
<b>4 Operation</b> .....	<b>6</b>
<b>5 Typical Installation Examples</b> .....	<b>7</b>
<b>6 Tank Installation and Commissioning</b> .....	<b>9</b>
6.1 Connection to heat sources .....	9
6.2 Heating element installation .....	9
6.3 Connection to water mains .....	9
6.4 Commissioning .....	9
<b>7 Installing Insulation on the Tank</b> .....	<b>10</b>
7.1 Insulation description .....	10
7.2 How to install the insulation .....	10
7.3 Warranty on insulation .....	10
<b>8 Maintenance</b> .....	<b>11</b>
<b>9 Disposal</b> .....	<b>11</b>
<b>10 Warranty</b> .....	<b>11</b>

# 1 - Description

DUO N P Thermal Stores are intended for storing and subsequent distribution of thermal energy from various heat sources like solid-fuel boilers, heat pumps, electric boilers etc. A DHW tank is integrated inside the thermal store. For a better thermal layering, the tank volume is separated by a metal plate. The thermal store shall to be connected to a closed heating system with forced circulation.

For proper operation of a tank, it is necessary to have an optimum hydraulic design of the entire heating system, i.e. position of circulation pumps for both heat sources and heating circuits, valves, check valves etc. When more heat sources shall be combined, it is recommended to use a smart controller for both the heat source and heat consumer sections of a heating circuit, i.e. also for charging and discharging a thermal store.

## 1.1 - Models

Models DUO 390/130 N P, DUO 600/200 N P, DUO 750/200 N P, DUO 1000/200 N P, DUO 1700/200 N P permitting installation of electric heating elements and other external heat sources.

## 1.2 - Tank protection

The inner DHW tank is made of stainless steel. A chain-type magnesium anode is installed in it for an increased level of protection. The thermal store has no inner surface finish, the outer surface is lacquered.

## 1.3 - Thermal insulation

Thermal insulation is available as a separate item. For easier handling, the insulation shall not be fitted on the tank until it reaches its definite place of installation. The insulation is made of fleece, 100 mm thick, with a hard polystyrene surface. It is closed by quick locks.

## 1.4 - Packaging

Thermal stores are delivered standing, each screwed to its pallet, packed in bubble wrap. The tank is then shrink-wrapped together with its pallet.

**It is forbidden to transport and/or store the thermal stores in a horizontal position.**

# 2 - General Information

This Manual is an integral and important part of the product and must be handed over to the User. Read carefully the instructions in this Manual as they contain important information concerning safety, installation, operation and maintenance. Keep this Manual for later reference. The appliance shall be installed by a qualified person according to valid rules and Manufacturer's instructions.

This appliance is designed to accumulate thermal energy of heating water and distribute it subsequently. It must be connected to a heating system and heat sources. This appliance is suitable also for storage hot water heating.

Using the thermal store for other purposes than above described is forbidden and the manufacturer accepts no responsibility for damage caused by improper or wrong use or filling procedure.

***Prior to filling the thermal store, fill and pressurize the inner DHW tank first!!!***

# 3 - Technical Data and Dimensions of Regulus DUO N P series

## Regulus DUO 390/130 N P Thermal Store

Dimensions		DUO 390/130 N P	
	<b>CONNECTIONS</b>		
	pos.	descriptions	connection
<b>Heat sources</b>			
B1	Incoming from heat source	G 1" F	780
B2	Return to heat source	G 1" F	210
B3	Incoming from heat source	G 1" F	1630
B4	Return to heat source	G 1" F	880
B5	Incoming from heat source	G 1" F	1540
<b>Heating system</b>			
H1	Flow to heating system	G 1" F	780
H2	Return from heating system	G 1" F	210
<b>Electric heating elements</b>			
E1	Electric heating element for space heating	G 6/4" F	720
E2	Electric heating element for space heating	G 6/4" F	720
E3	Electric heating element for DHW heating	G 6/4" F	980
E4	Electric heating element for PV system	G 6/4" F	270
<b>DHW heating</b>			
W1	Cold water	G 1" M	1910
W2	Hot water	G 1" M	1910
W3	Circulation	G 1" M	1910
N	Anode	G 1" F	1855
<b>Control and safety</b>			
C1	Temperature sensor – space heating	G 1/2" F	750
C2	Temperature sensor – DHW heating	G 1/2" F	510
C3	Temperature sensor – DHW heating	G 1/2" F	1160
C4	Temperature sensor – DHW heating	G 1/2" F	1020
T	Thermometer	G 1/2" F	1630
M	Manometer	G 1/2" F	510
P	Safety valve	G 1/2" F	400
<b>Air release</b>			
O	Air vent valve	G 1/2" F	1885

	DUO 390/130 N P
Code - tank	19131
Code - insulation	19318
Standing loss	87 W
Total tank volume	396 l
Fluid volume in tank	273 l
Volume of immersed DHW tank	123 l
Max. working temperature in tank	95 °C
Max. working temperature in DHW tank	95 °C
Max. working pressure in tank	3 bar
Max. working pressure in DHW tank	6 bar
Tank diameter	550 mm
Tank diameter with insulation	750 mm
Tank overall height	1910 mm
Tipping height without insulation	1950 mm
Empty weight	102 kg
Electric heating element	models ETT-C, F, M, P
Number and max. length of heating elements	4 x 500 mm

# Regulus DUO 600/200 N P, 750/200 N P, 1000/200N P, 1700/200 N P Thermal Stores

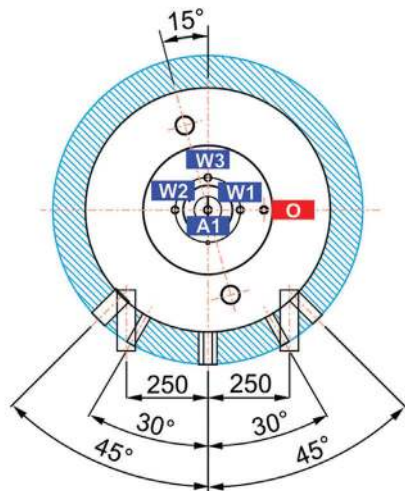
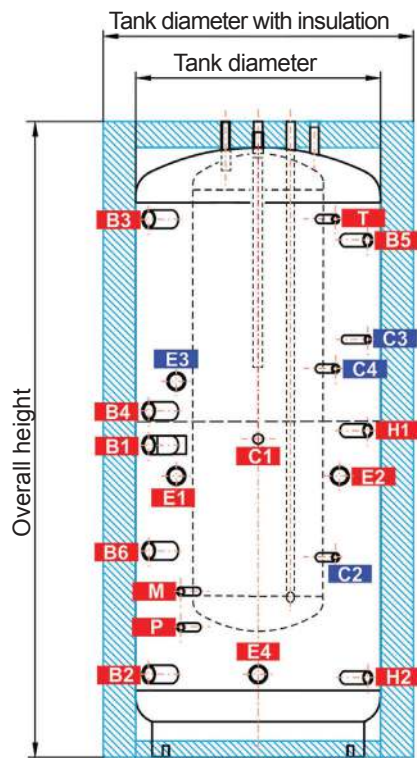

		DUO 600/200 N P	DUO 750/200 N P	DUO 1000/200 N P	DUO 1700/200 N P
pos.	connection	height [mm]			
<b>Heat sources</b>					
B1	G 6/4"F	985	960	1115	1150
B2	G 6/4"F	235	255	300	335
B3	G 6/4"F	1635	1655	1700	1675
B4	G 6/4"F	1090	1065	1220	1255
B5	G 1"F	1570	1590	1635	1610
B6	G 6/4"F	660	635	785	820
<b>Heating system</b>					
H1	G 1"F	1030	1005	1160	1195
H2	G 1"F	225	245	290	325
<b>Electric heating elements</b>					
E1	G 6/4"F	890	865	1020	1055
E2	G 6/4"F	890	865	1020	1055
E3	G 6/4"F	1180	1055	1310	1295
E4	G 6/4"F	235	255	300	335
<b>DHW heating</b>					
W1	G 1"M	1935	1980	2080	2080
W2	G 1"M	1935	1980	2080	2080
W3	G 1"M	1935	1980	2080	2080
A1	G 1"F	1880	1925	2025	2025
<b>Control and safety</b>					
C1	G 1/2"F	1000	975	1130	1165
C2	G 1/2"F	625	615	740	775
C3	G 1/2"F	1310	1285	1440	1425
C4	G 1/2"F	1220	1195	1350	1335
T	G 1/2"F	1635	1655	1700	1675
M	G 1/2"F	510	510	510	510
P	G 1/2"F	400	400	400	400
<b>Air release</b>					
O	G 1/2"F	1910	1955	2055	2055

	DUO 600/200 N P	DUO 750/200 N P	DUO 1000/200 N P	DUO 1700/200 N P
Code - tank	19147	19141	19143	19137
Code - insulation	19330	19333	19334	19354
Standing loss	102 W	118 W	130 W	175 W
Total tank volume	559 l	757 l	903 l	1682 l
Fluid volume in tank	385 l	583 l	729 l	1508 l
Volume of immersed DHW tank	174 l	174 l	174 l	174 l
Max. working temperature in tank	95 °C	95 °C	95 °C	95 °C
Max. working temperature in DHW tank	95 °C	95 °C	95 °C	95 °C
Max. working pressure in tank	3 bar	3 bar	3 bar	3 bar
Max. working pressure in DHW tank	6 bar	6 bar	6 bar	6 bar
Tank diameter	650 mm	750 mm	800 mm	1100 mm
Tank diameter with insulation	850 mm	950 mm	1000 mm	1300 mm
Tank overall height	1935 mm	1980 mm	2080 mm	2080 mm
Tipping height without insulation	1970 mm	2040 mm	2120 mm	2200 mm
Empty weight	126 kg	147 kg	167 kg	225 kg
Electric heating element	type ETT-C, F, M, P			
Number and max. length of heating elements	3x 500 mm into E1-E3 connections, 700 mm into E4 connection	3 x 635 mm into E1-E3 connections, 755 mm into E4 connection	3 x 700 mm into E1-E3 connections, 755 mm into E4 connection	4 x 955 mm

## 4 - Operation

This tank is designed to accumulate thermal energy in household or industrial applications, however always in closed pressure circuits with forced circulation.

Hot water is heated by heating water inside the integrated DHW tank. It connects with fittings to both cold and hot water piping, possibly also to a hot water recirculation circuit. When hot water is drawn from an outlet point, cold water flows into the immersed DHW tank and heats up from the heating water in the thermal store to a temperature set by the thermostat placed in the sheath of the DHW tank, or in a heating system controller. Hot water temperature should be set to 60-65 °C. This temperature guarantees the best operation and at the same time, it prevents formation of Legionella bacteria.

# 5 - Typical Installation Examples

## Variant 1: RegulusBOX with heat pump

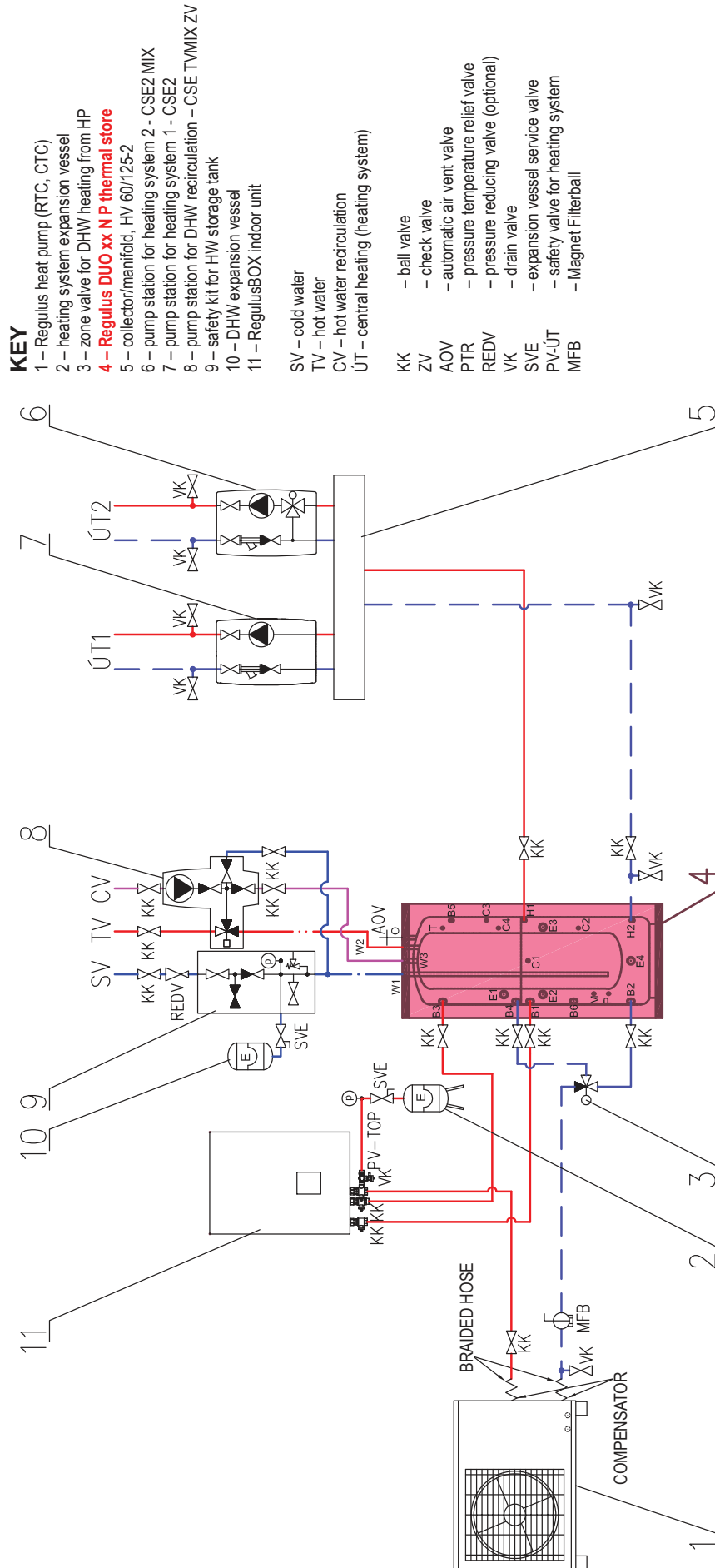

## VARIANT 2: Heat pump with hydronic fireplace insert and el. heating elements

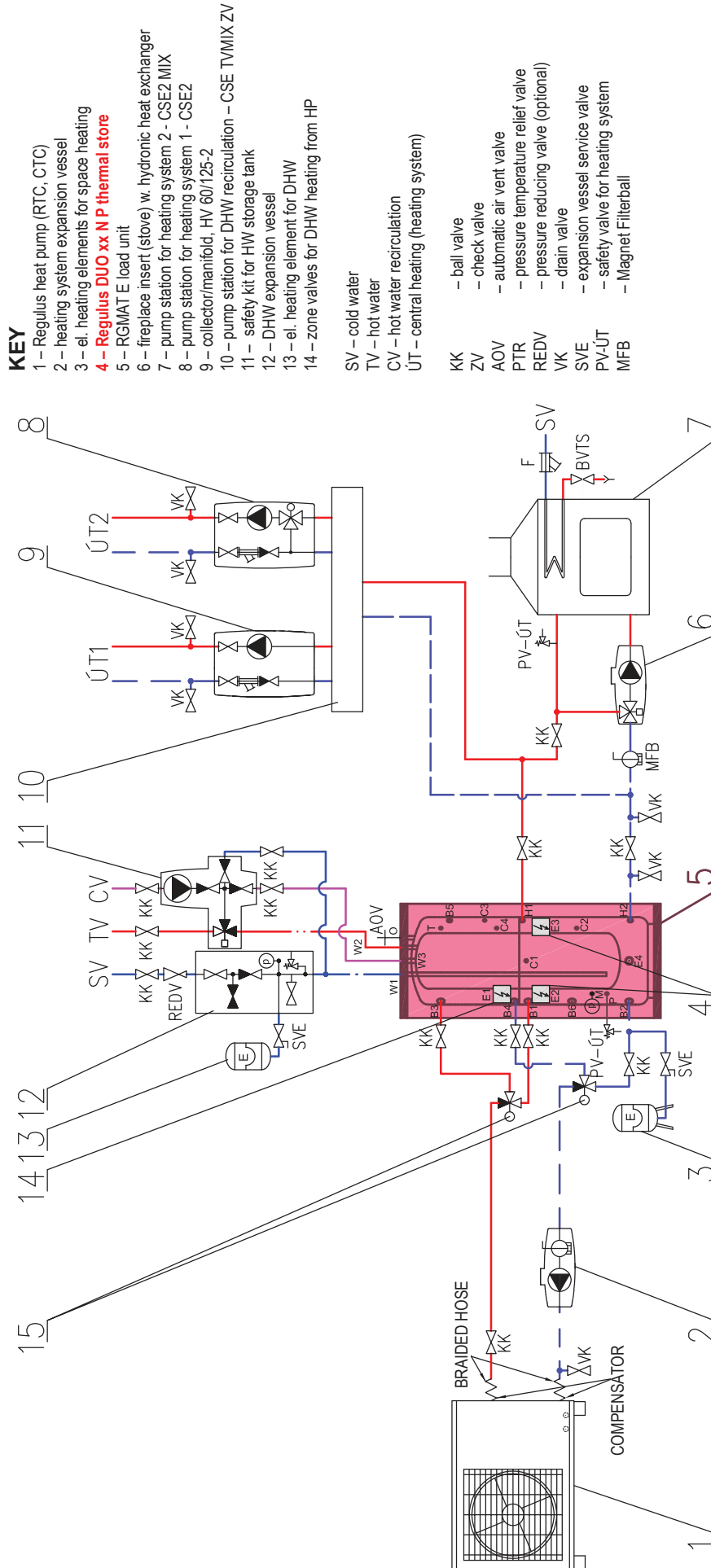



# 6 - Tank Installation and Commissioning

Installation must meet valid rules and may be done only by qualified staff.

After the tank is installed and connected to an existing heating system, it is recommended to clean the entire heating system using a suitable cleaning agent, e.g. BP 400. Anti-corrosion protective liquid should be also used, e.g. BP 100 Plus.

The electric heating element shall be wired by a professionally qualified person only.

**Defects caused by improper installation, use or handling are not covered by warranty.**

## 6.1 - Connection to heat sources

Place the tank on the floor, as close to your heat source as possible and level it. Connect the heating system according to one of the schematic diagrams - see Chap. 5. Install a drain valve at the lowest point of the tank. Install an air vent valve at the highest point of the system. Insulate all the connection piping.

## 6.2 - Heating element installation

Electric heating elements shall be installed into G 6/4" side connections. They can be connected either directly (elements with integrated thermostat) or via the controller of the entire heating system. Electric heating elements shall be wired by a professionally qualified person only.

**Warning: Electric heating elements shall be protected by a safety thermostat.**

## 6.3 - Connection to water mains

The connection to the tank, including the fittings, is shown in the diagram of the recommended connections in Chap. 5. DHW piping shall be done according to valid rules. Installation of a pressure reducing valve on the immersed tank inlet is recommended. For water mains pressure above 6 bar a pressure reducing valve is necessary. To prevent water loss, we recommend installing an expansion vessel at the cold water inlet with a minimum volume of 4% of the total volume of water in the DHW piping, including heat exchangers, circulation pipes, etc. (usually 8 l). Installation of an expansion vessel is one of the necessary conditions of the extended warranty. Should the water be too hard, install a water softener upstream of the tank. In case the water contains mechanical impurities, install a filter.

**Table of limit values for total dissolved solids in hot water**

Description	pH	Total dissolved solids (TDS)	Ca	Chlorides	Mg	Na	Fe
Max. value	6,5 - 9,5	600 mg/l	40 mg/l	100 mg/l	20 mg/l	200 mg/l	0,2 mg/l

## 6.4 - Commissioning

Ground the tank before commissioning.

***During commissioning, the immersed hot water tank shall be filled and pressurized first, after that the thermal store can be filled. If the thermal store was filled first, the DHW tank would get damaged!!!***

The tank shall be filled up together with the heating system, respecting valid standards and rules. In order to minimize corrosion, special additives for heating systems should be used. The quality of heating water depends on the quality of filling water at commissioning, on the top-up water and on the frequency of topping up. This has a strong influence on the lifetime of heating systems. Poor quality of heating water may cause problems like corrosion or incrustation, esp. on heat transfer surfaces.

**Quality of DHW shall meet the conditions shown in the Table of limit values for total dissolved solids in hot water in Chap. 6.3.**

Fill the heating system with the appropriate fluids and air-bleed the entire system. Check all connections for leaks and verify the system pressure. Set the heating controller in compliance with the documentation and manufacturer's recommendations. Check regularly the proper function of all control and adjustment elements.

# 7 - Installing Insulation on the Tank

## 7.1 - Insulation description

Thermal insulation is part of the thermal store to prevent its heat loss. Insulation for this type of thermal store is installed only at the place of the thermal store installation for easier handling.

### Warning

Insulation installation shall be done in two persons. Do not use any tools for installation. Keep away from open fire.

## 7.2 - How to install the insulation

1. Fix the tank following installation instructions.
2. Wrap the insulation around the tank carefully. Check that the insulation adheres to its body perfectly. This can be reached by rubbing and patting the insulation by hand from its centre evenly in both directions until the insulation adheres to the tank's surface completely and no bubbles are left.
3. Use the holes for connections as a rest during the insulation installation.
4. At least one person presses the insulation to the tank, pulling both ends together. The other person closes the insulation lock.
5. Put on the upper insulation and cover.
6. Push on the covering plastic rosettes depending on the size of connections.
7. Finish the tank installation in compliance with the respective instructions and valid standards and rules

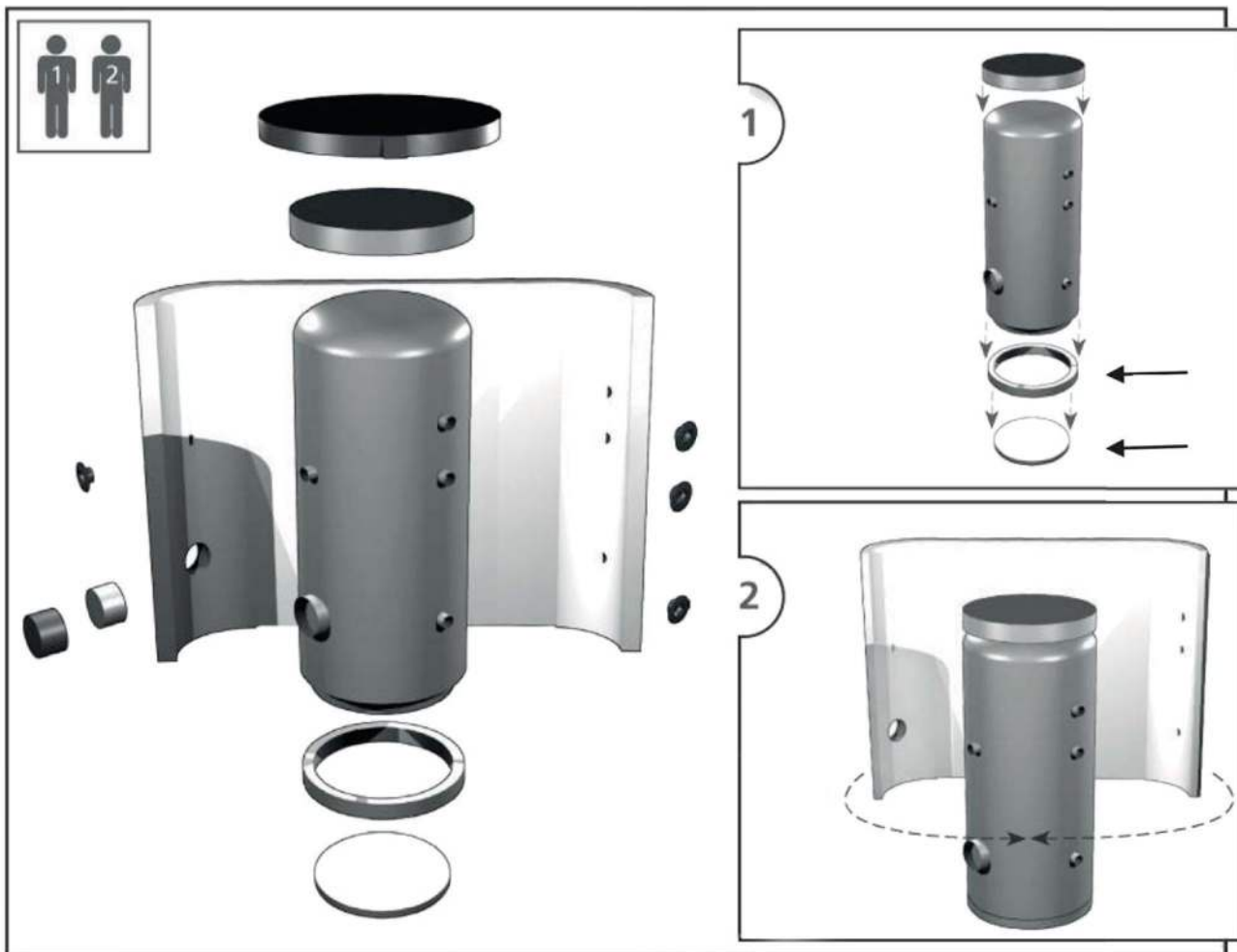

## 7.3 - Warranty on insulation

- Warranty shall become null and void if:
  - the procedure described in the Installation Manual was not respected,
  - the product was used for other purposes than intended.
- Warranty does not cover:
  - usual wear and tear,
  - damage caused by fire, water, electricity or a natural disaster,
  - defects caused by failure to use the product in compliance with its intended purpose, by improper use and insufficient maintenance,
  - defects caused by mechanical damage to the product,
  - defects caused by tampering or incompetent repair.

## 8 - Maintenance

If the tank is fitted with a heating element, disconnect it from the mains first. Clean the exterior of the tank with a soft cloth and a mild detergent. Never use abrasive cleaners or solvents.

Check all connections for leaks.

The thermal stores come with an anti-corrosion sacrifice magnesium anode rod as standard. The condition of the anode rod shall be checked within 12 months after commissioning and subsequently always not later than 12 months after the last check. In locations where water contains more ferrites or calcites, it is recommended to check the anode rod every 6 months. If more than one third of its total volume is consumed, the anode rod shall be replaced with a new one. Disregarded of its state, the magnesium anode rod shall be always replaced with a new one within 24 months from commissioning.

**When replacing the magnesium anode rod, first reduce the pressure in the thermal store to atmospheric pressure, then reduce the pressure in the DHW tank. Replace the anode rod and pressurize the DHW tank, then pressurize the thermal store.**

**If the tank gets damaged due to neglected replacement or wrong replacement procedure of the magnesium anode rod, the warranty cannot be claimed.**

## 9 - Disposal

Packaging shall be disposed of in compliance with the valid rules. When the product reaches the end of its life, it shall not be disposed of as household waste. It shall be dropped off at a Local Waste Recycling Center. Insulation shall be recycled as plastic and the steel vessel as scrap iron.

## 10 - Warranty

Transporting and/or storing the thermal store in a horizontal position is considered a breach of warranty conditions!

